

Villa - Fritidshus



**ANDERSSONS
TRÄHUSFABRIK AB**

VÄNNÄSVÄGEN 126 • 956 92 ÖVERKALIX

Tel: 0926-210 35 • Fax: 0926-211 40

www.anderssonstrahus.se

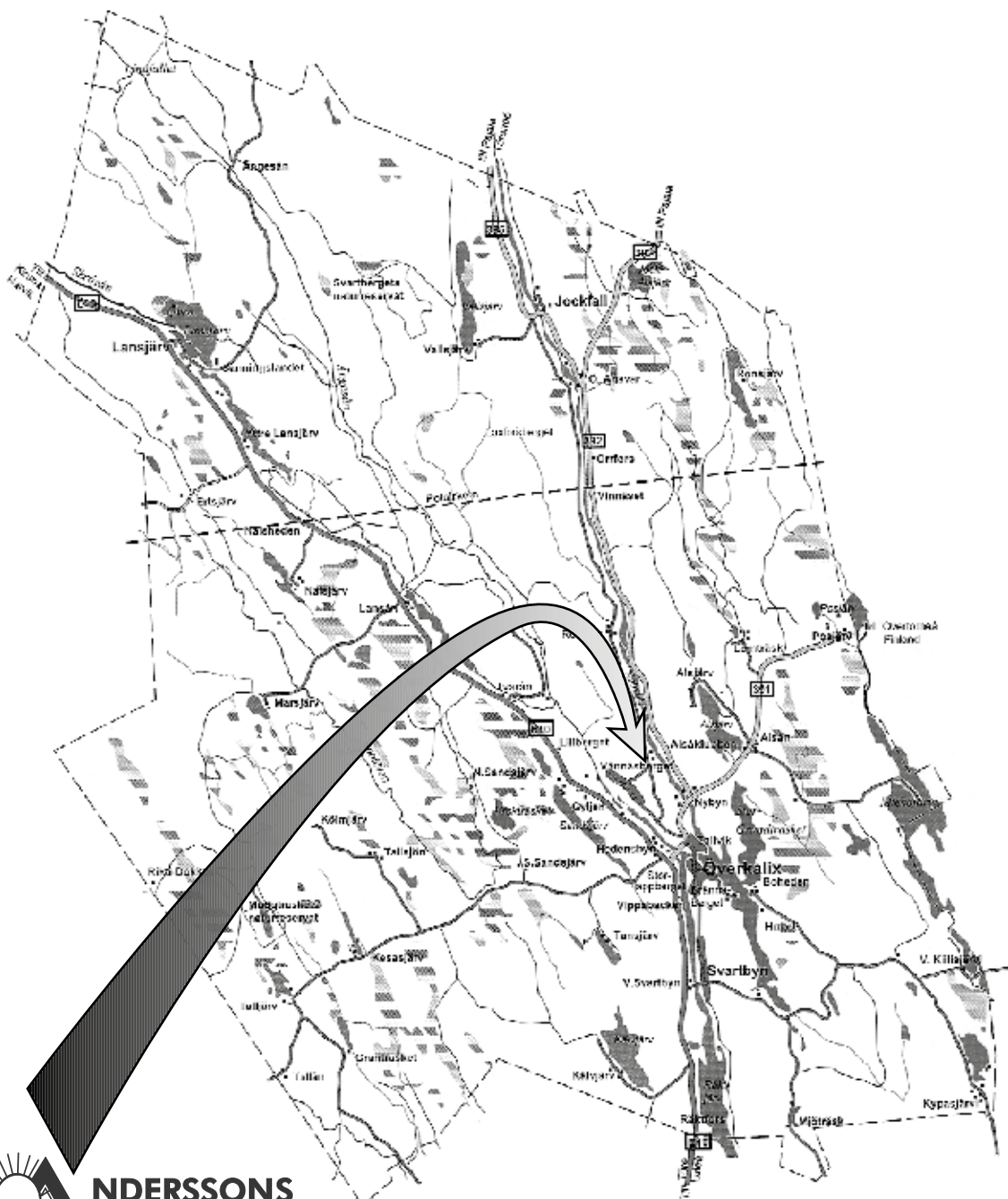

**NDERSSONS
TRÄHUSFABRIK AB**

VÄNNÄSVÄGEN 126 - 956 92 ÖVERKALIX
Tel: 0926-210 35. Fax: 0926-211 40
www.anderssonstrahus.se

Vinnäset	30-00	Sid. 3
Räktforsen	30-01	Sid. 4
Långforsen	30-02	Sid. 5
Kalixforsen	30-03	Sid. 6
Kalixforsen	30-04	Sid. 7
Kalixforsen	30-05	Sid. 8
Kamlungeforsen	30-06	Sid. 9
Porjus	30-07	Sid. 10
Åkerbärsstugan	30-08	Sid. 11
Stora Sjöfallet	30-09	Sid. 12
Stora Sjöfallet	30-10	Sid. 13
Stora Sjöfallet	30-11	Sid. 14
Orrforsen	30-12	Sid. 15
Storforsen	30-13	Sid. 16
Akkats	30-14	Sid. 17
Akkats	30-15	Sid. 18
Akkats	30-16	Sid. 19
Laxforsen	30-17	Sid. 20
Renforsen	30-18	Sid. 21
Renforsen	30-19	Sid. 22
Renforsen	30-20	Sid. 23
Brudforsen	30-21	Sid. 24
Ängesån	30-22	Sid. 25
Fällforsen	30-23	Sid. 26
Harsprånget	30-24	Sid. 27
Harsprånget	30-25	Sid. 28
Bönkroken	30-26	Sid. 29
Krokforsen	30-27	Sid. 30
Krokforsen	30-28	Sid. 31
Jockfall	30-29	Sid. 32
Vännässtugan	30-30	Sid. 33
Linafallet	30-31	Sid. 34
Linafallet	30-32	Sid. 35
Storforsen	30-33	Sid. 36
Fjällsippan	30-34	Sid. 37
Linafallet	30-35	Sid. 38
Linafallet	30-36	Sid. 39
Solgården		Sid. 40
Vännäsgården		Sid. 41
Norrgård		Sid. 42

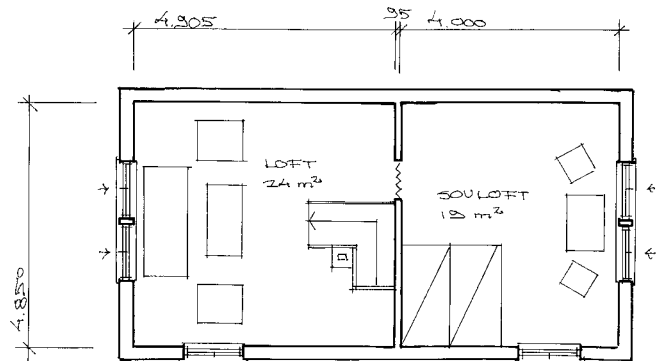

PLAN LOFTET

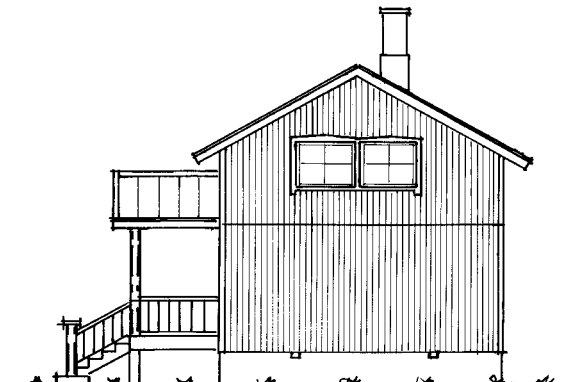

GAVELFASAD

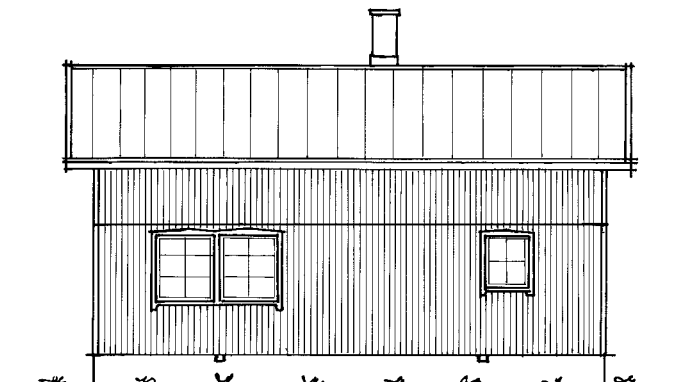

SIDOFASAD

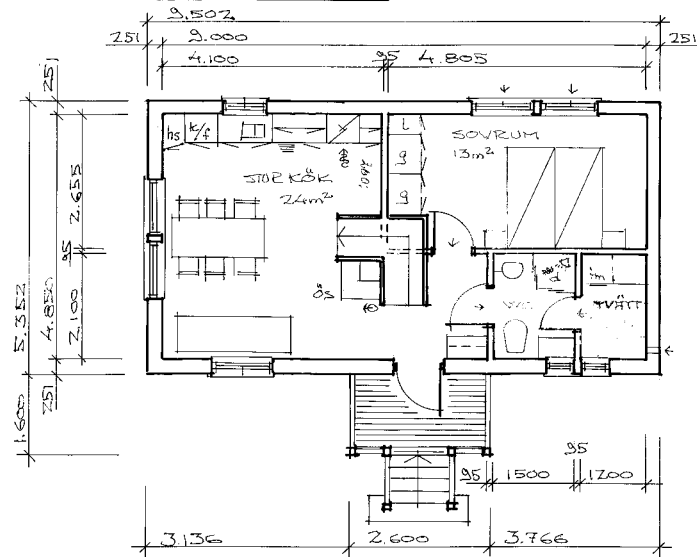

PLAN BOTTENVÄNING

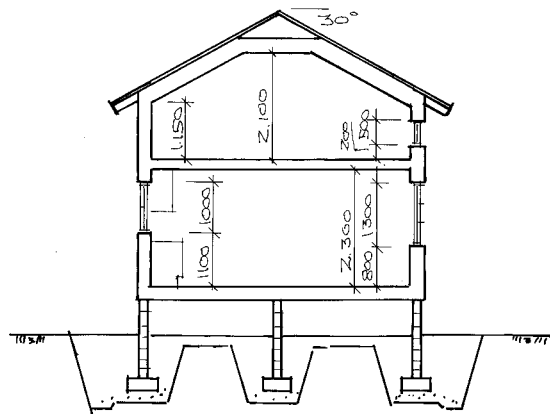

SEKTION

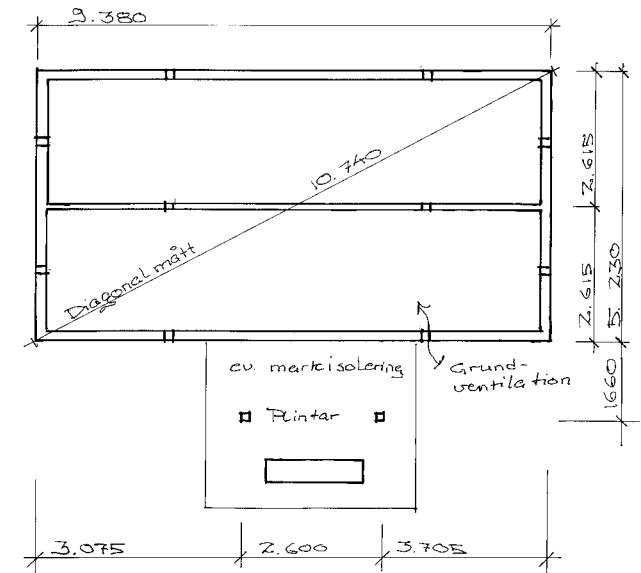

GRUNDPLAN



ENTREFASAD



GAVELFASAD

FRITIDSHUS VINNÄSET BYÅ 50 m²
 LOFT 43 m²
 PLANER, FASADER,
 SEKTION OCH GRUNDPLAN

Ritad av Sixten Riström tel 0926-77721
 Porsjätte

Skala 1:100

03 30-00

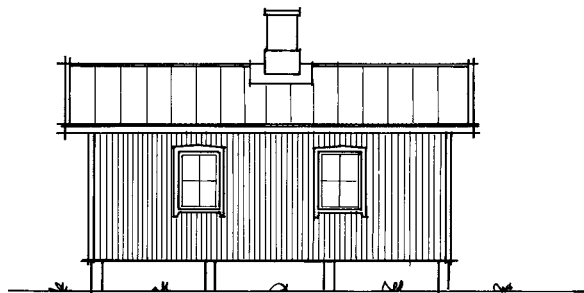

SIDOFAJAD

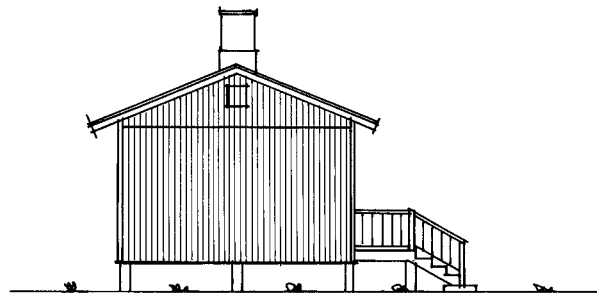

GAVELFAJAD

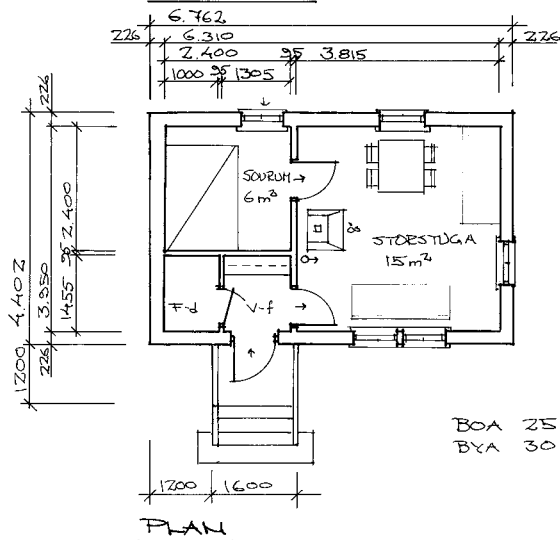

PLAN

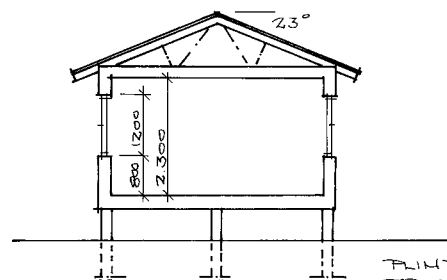

SEKTION

FLINTAR TILL
FRÖSTFRITT DJUP

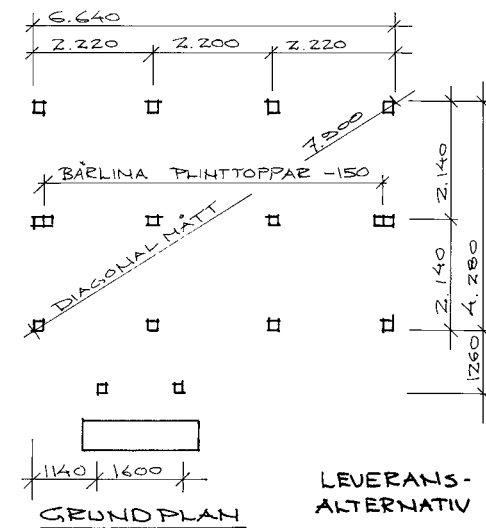

GRUNDPLAN



ENTREFAJAD

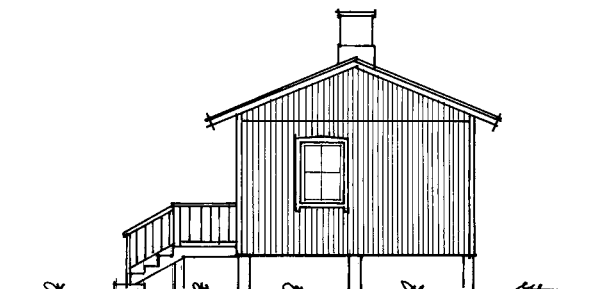

GAVELFAJAD

FRITIDSHUS RÅKTFORSEN BYA30 m²
PLAN, FASADER,
SEKTION OCH
GRUNDPLAN

Ritad av Sixten Riström tel 0928-77721
Överkalix

30-01

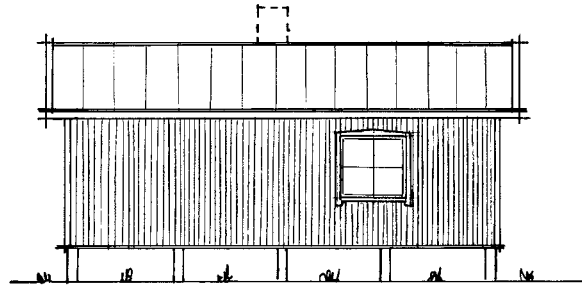

LÅNGFASAD

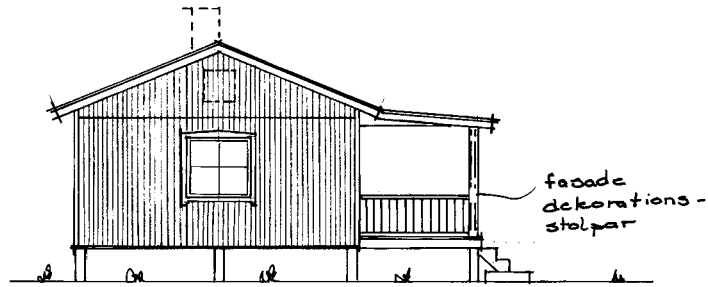

GÅVELFASAD

fasad
dekorations-
stolpar

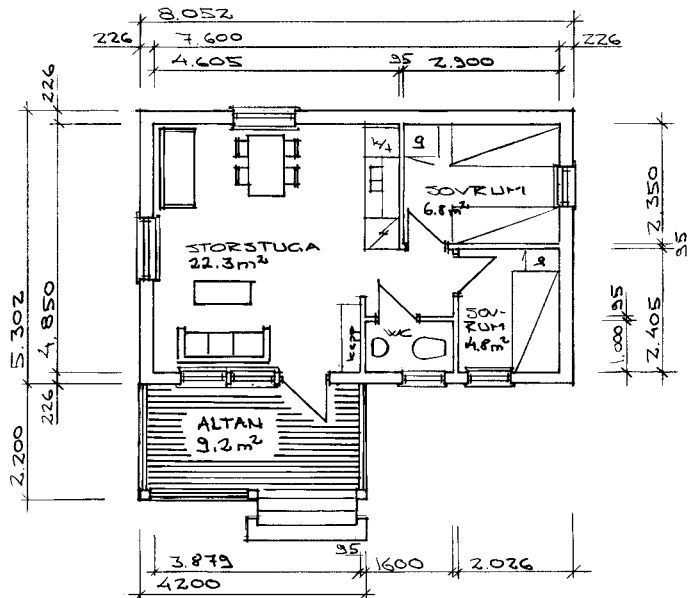

PLAN BYA 43.7m² ÖPA 9.3m²

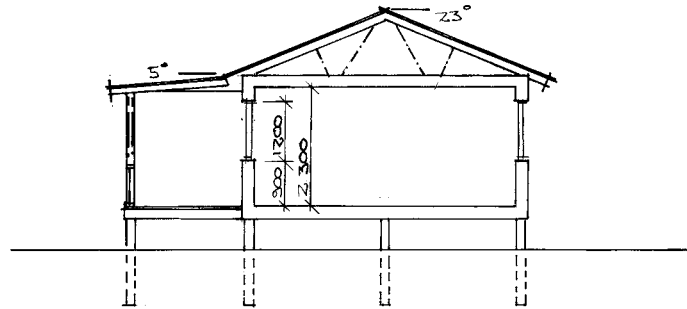

SEKTION

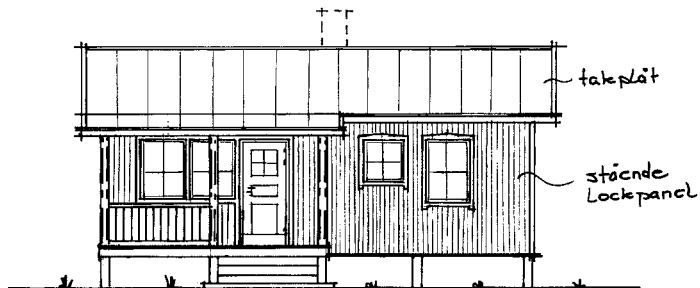

ENTREFFASAD

takplåt
stående
lockpanel

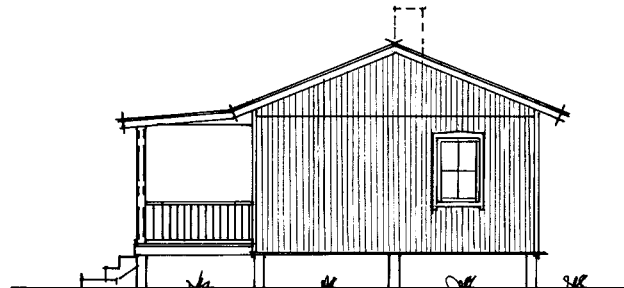

GÅVELFASAD

LEVERANSALTERNATIV 1

FRITIDSHUS LÅNGFORSEN BYA 43m²
PLAN, FASADER ÖPA 9m²
OCH SEKTION

Ritad av Sixten Riström tel 0926-77721
Överkalix

30-02

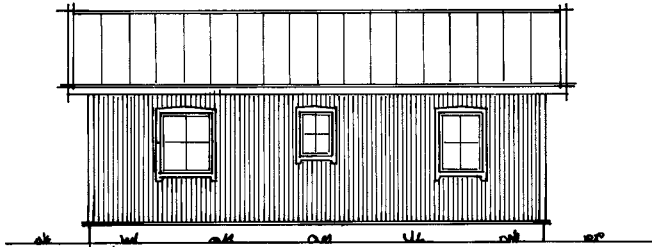

LÅNGFASAD

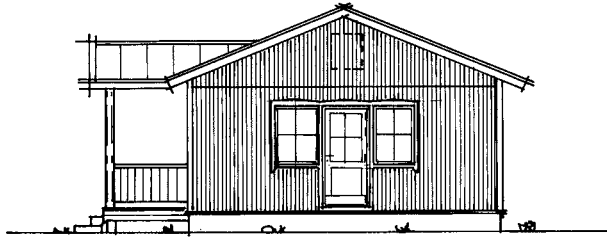

GAVELFASAD

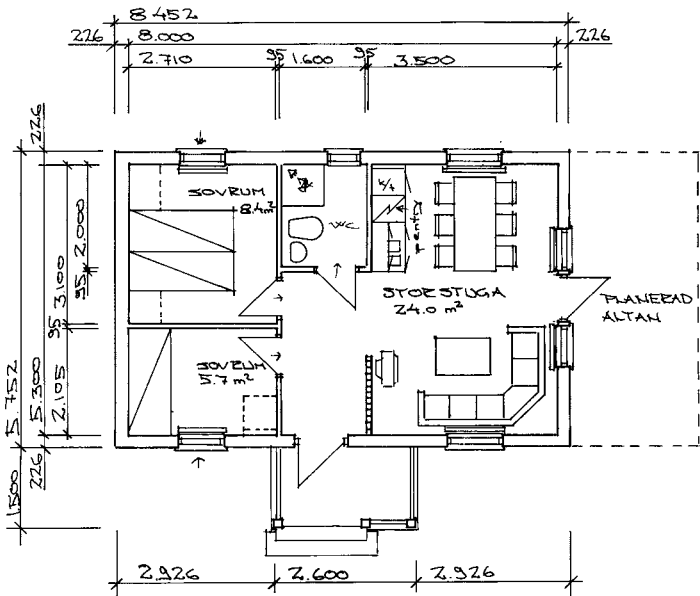

PLAN

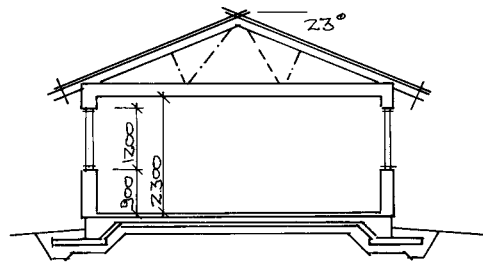

SEKTION

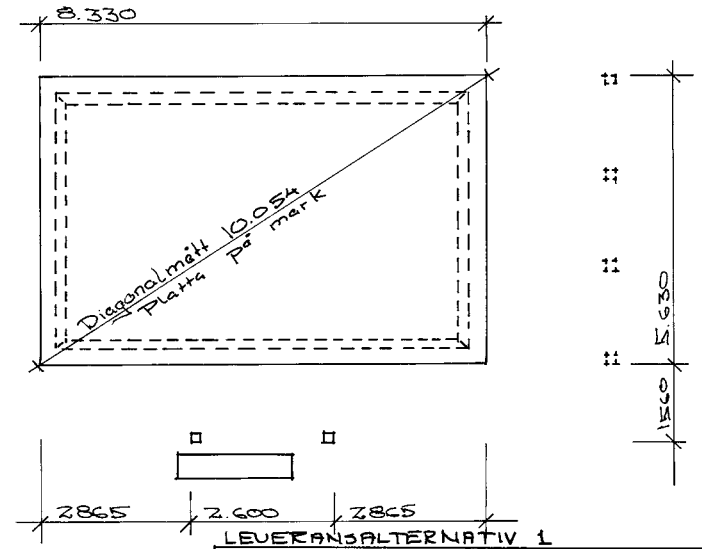

GRUNDPLAN



ENTREFASAD

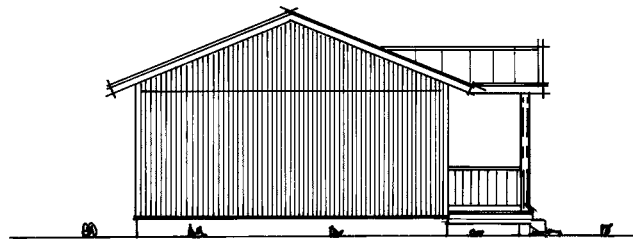

GAVELFASAD

FRITIDSHUS KALKFORSEM BYA 49 m²
 PLAN, FASADER,
 SEKTION OCH
 GRUNDPLAN

Ritad av Sixten Riström tel 0926-77721
 Överkalix

30-03

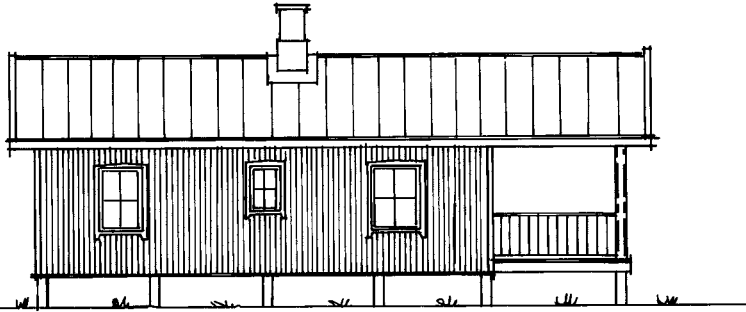

LÅNGFASAD

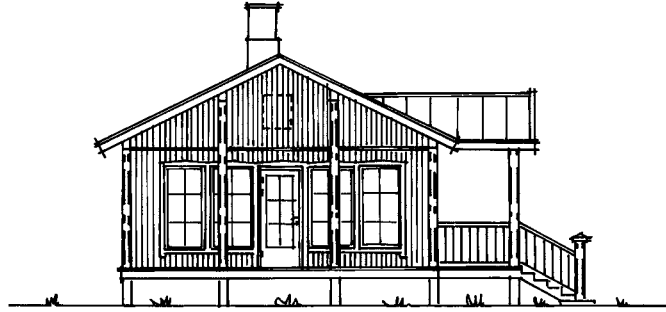

GAVELFASAD

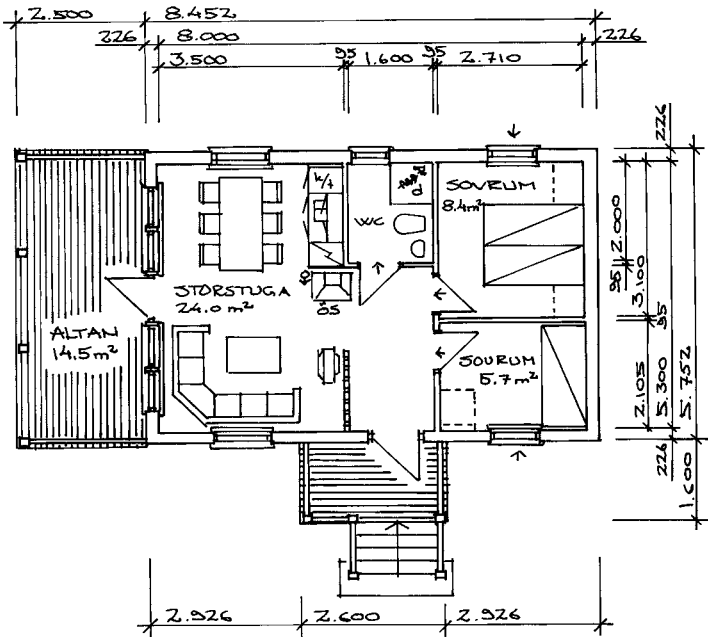

PLAN

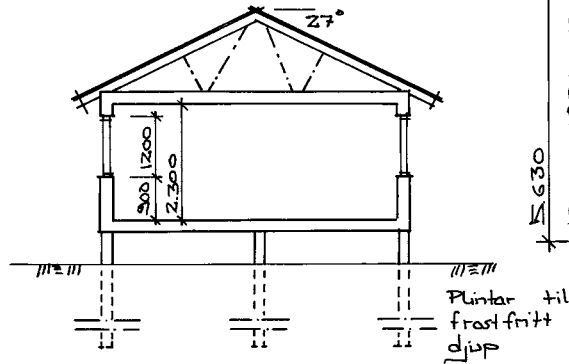

SEKTION

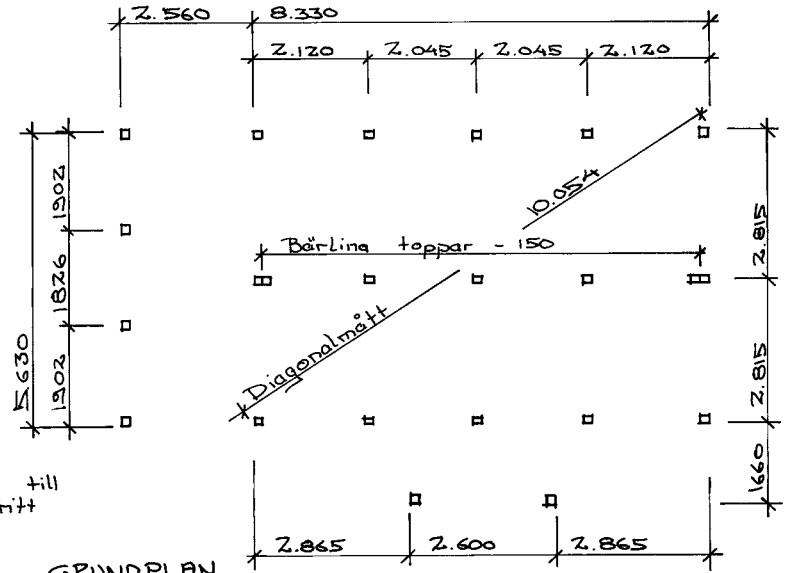

GRUNDPLAN

LEVERANSALTERNATIV 1



ENTREFASAD

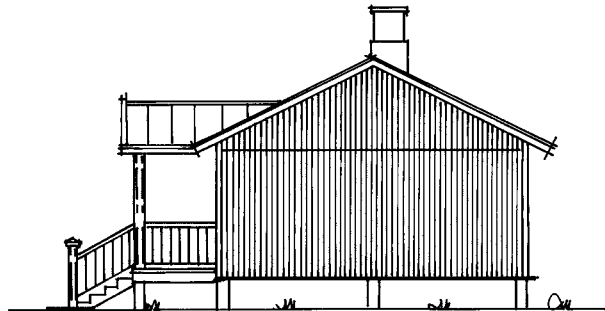

GAVELFASAD

FRITIDSHUS KALIXFORSJEN BYA 49m²
 PLAN, FASADER, ÖPA 19m²
 SEKTION OCH
 GRUND PLAN

Ritad av Sixten Riström tel 0926-77721
 Överkalix

30-04

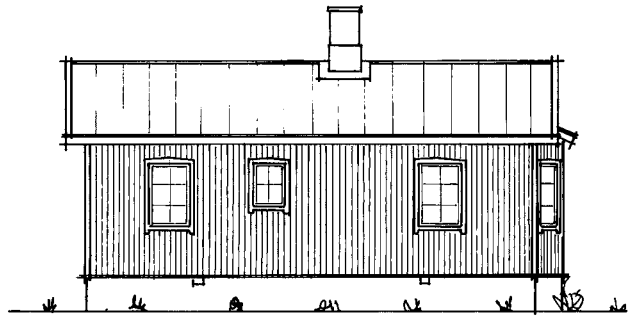

SIDOFAJAD

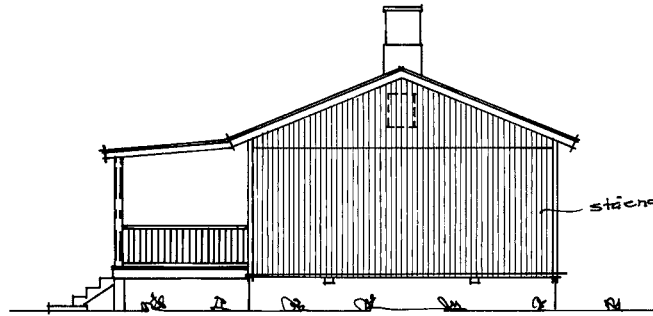

GAVELFAJAD

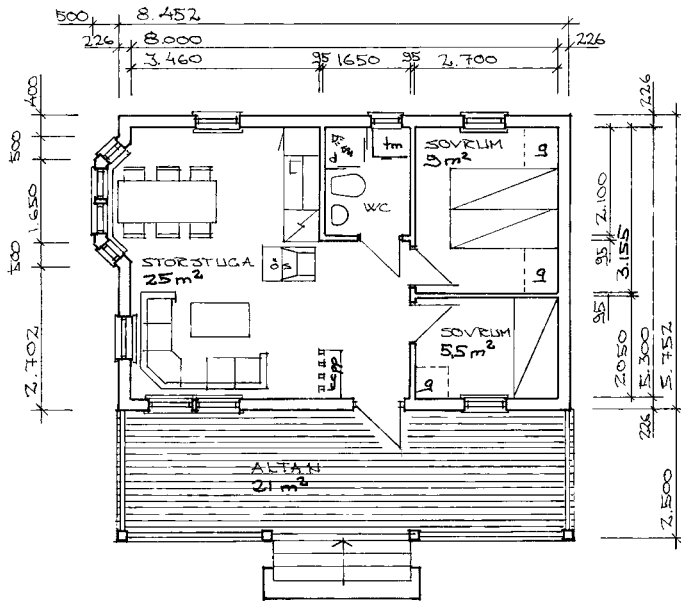

PLAN

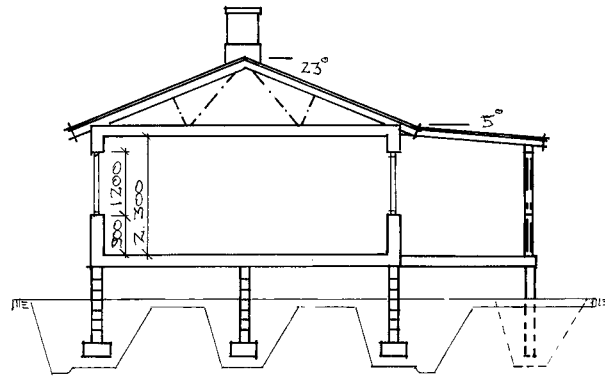

SEKTION

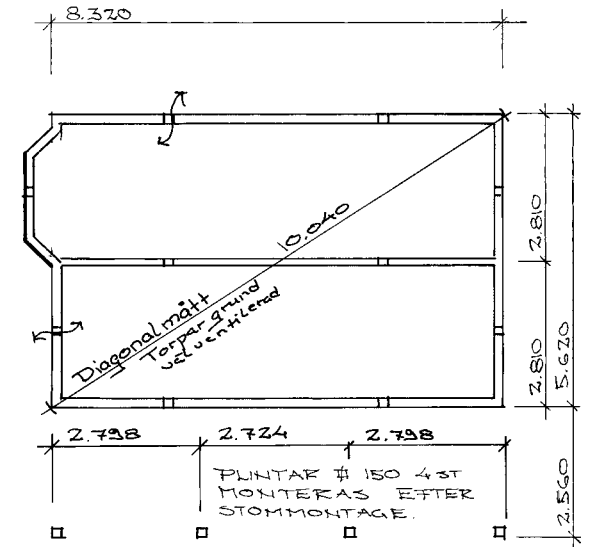

GRUNDPLAN

LEVERANSALTERNATIV 1

FRITIDSHUS KALIXFORSJEN BYA 50 m²
 PLAN, FASADER, ÖPA 21 m²
 SEKTION OCH
 GRUND PLAN

Ritad av Sixten Ristrom tel 0326-777 21
 Överkalix

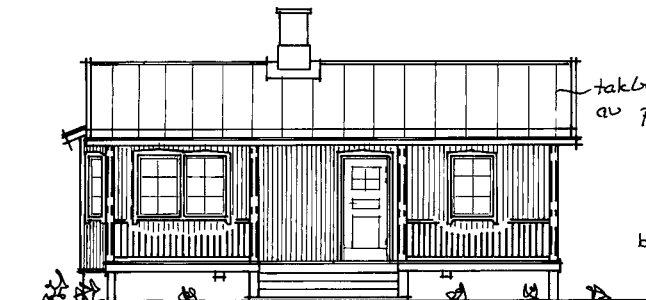

ENTREFAJAD



GAVELFAJAD

30-05

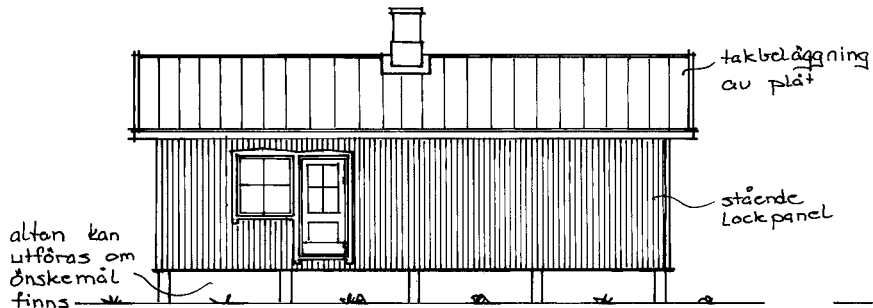

SIDOFASAD

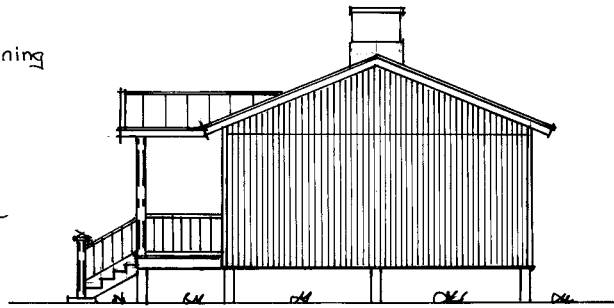

GAVELFASAD

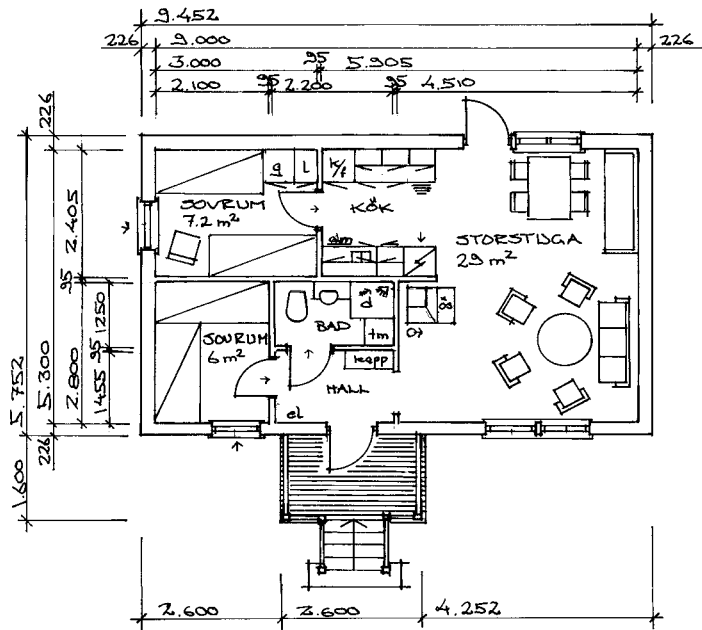

PLAN

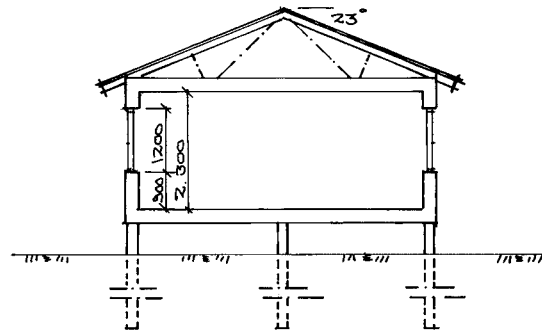

SEKTION

PLINTAR GRUND-
LÄGGES PÅ FÖST-
FRITT DJUP

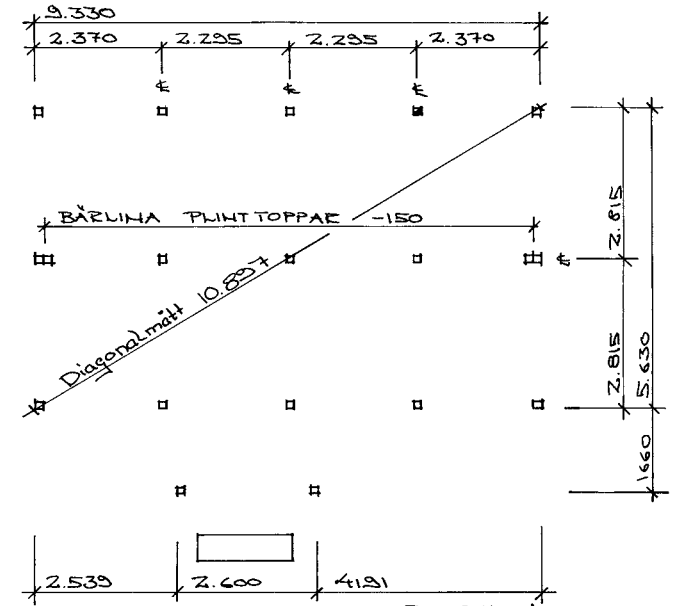

GRUNDPLAN

LEVERANSALTERNATIV 1



ENTREFASAD

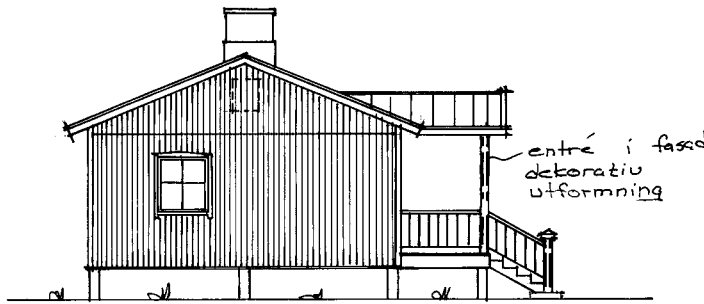

GAVELFASAD

FRITIDSHUS KÄMLUNGEFORSÉN
PLAN, FASADER, BYA 54 m²
SEKTION OCH
GRUNDPLAN

Ritad av: Sixten Riström tel 0926-77721
Övertelrix

30-06

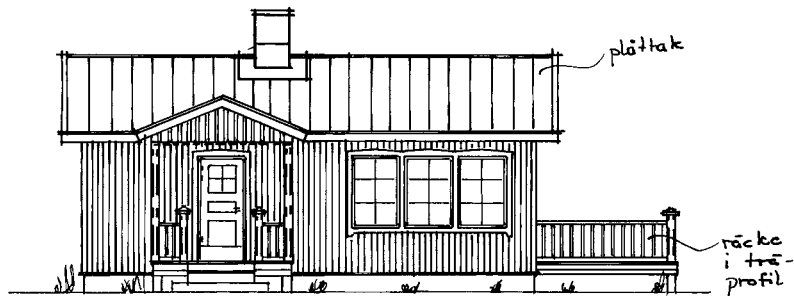

ENTREFASAD

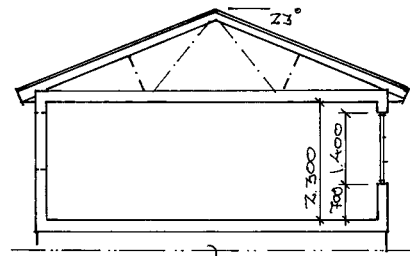

SEKTION

alternativa grundläggningssätt
plintgrund
torpargrund
platta på mark



GAVELFASAD

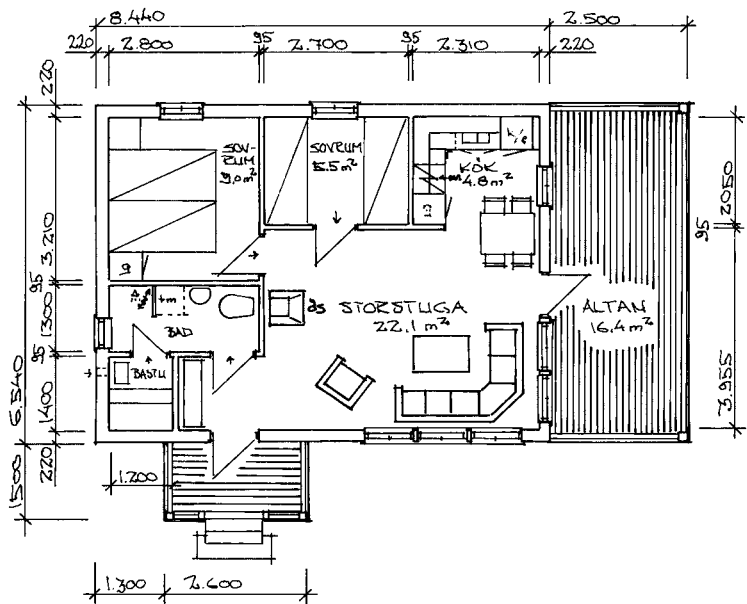

PLAN BYGGNADSYTA 55.2 m² ÖPPENYTA 20.3 m²

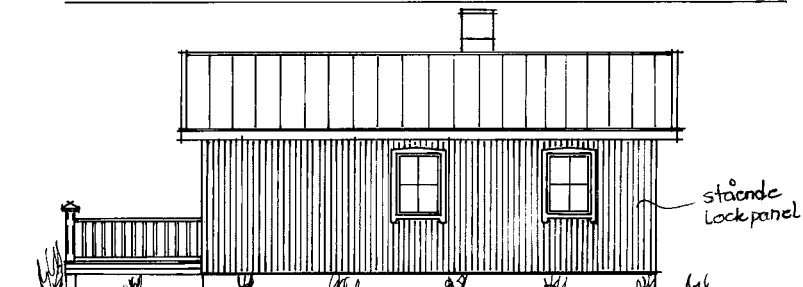

LÅNGFASAD

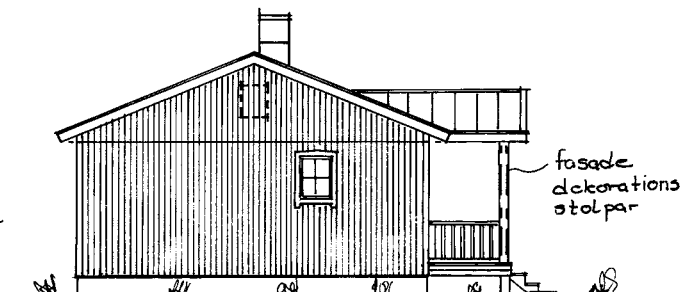

GAVELFASAD

LEVERANSALTERNATIV 1

FRITIDSHUS PORJUS BYA 55 m²

PLAN, FASADER
OCH SEKTION

Ritad av Sixten Ristrom tel 0926-11721
Överkalix

30-07

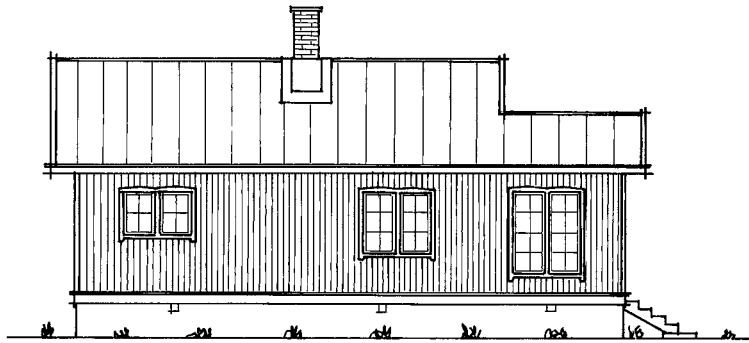

LÅNGFASAD

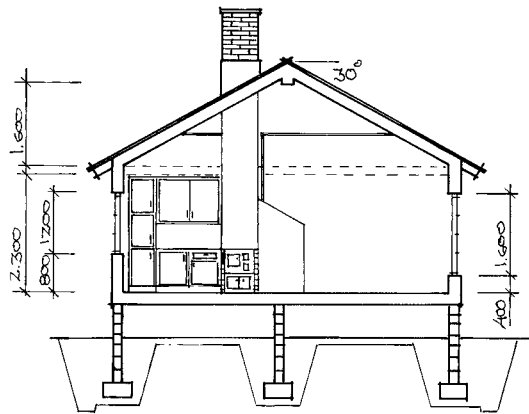

SEKTION

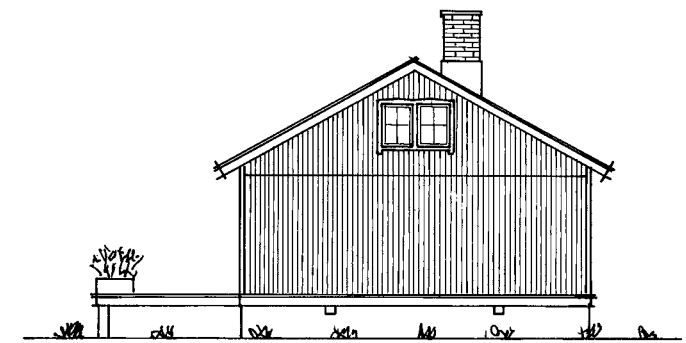

GAVELFASAD

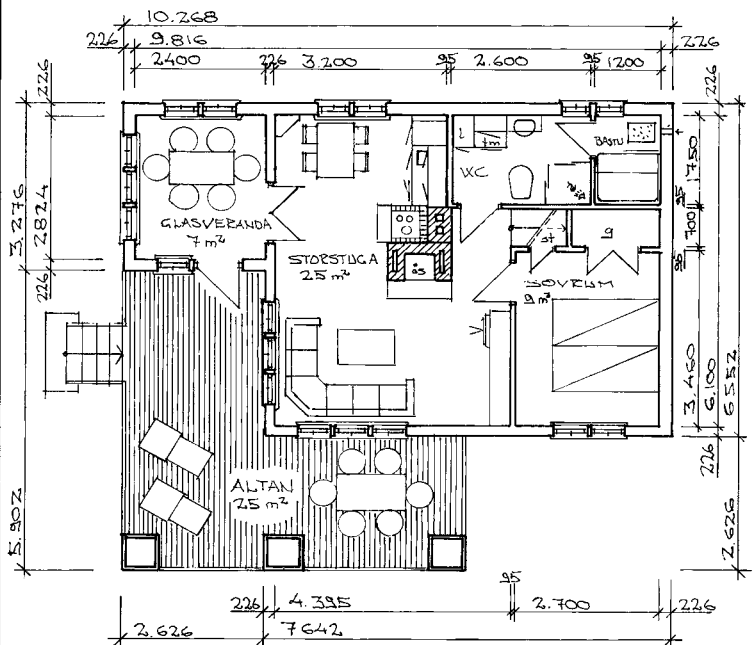

PLAN

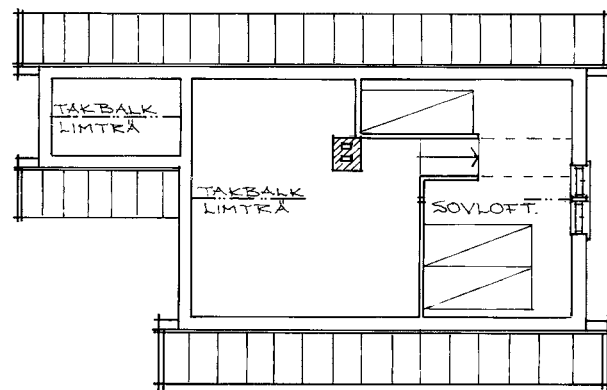

PLAN LOFT

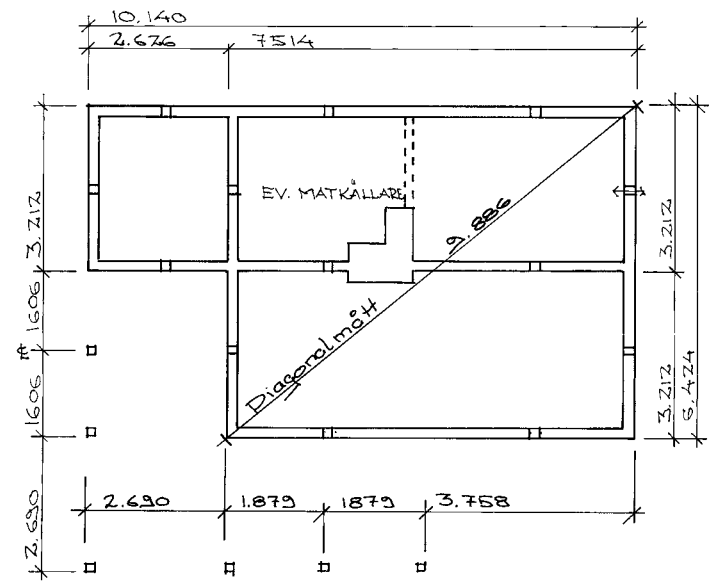

GRUNDPLAN

LEVERANSALTERNATIV 1

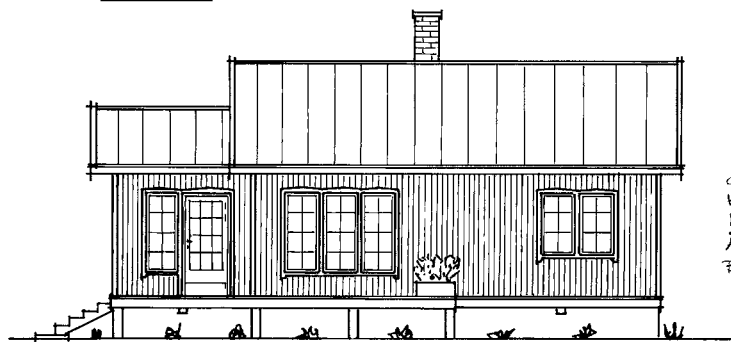

ENTREFASAD

GLASVERANDA
KAN UTFÖRAS
ISOLERAD FÖR
ÄRET TURT
BRUK

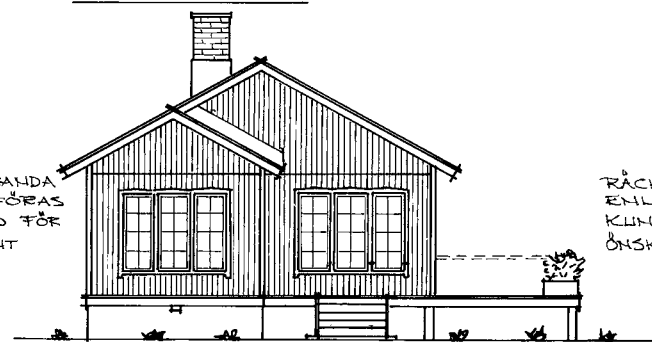

GAVELFASAD

RÄCKE
ENLIGT
KUND'S
ÖNSKEMÅL

FRITIDSHUS ÅKERBÄRSSTUGAN
PLANER, FASADER, BYA 58 m² +
SEKTION OCH LOFT
GRUNDPLAN
Ritad av Sixten Riström tel 0926-77721
Övertolix 6/5 1996

30-08

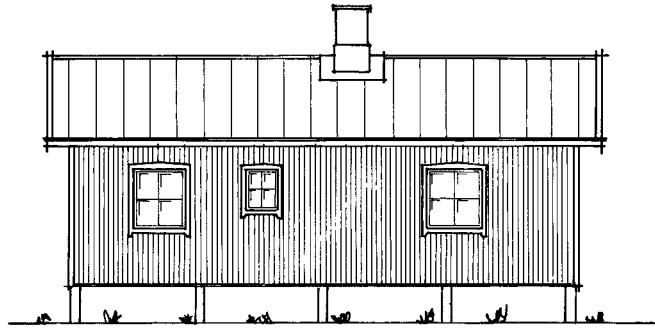

LÅNGFASAD

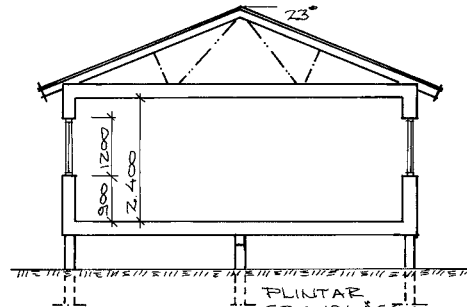

SEKTION



GAVELFASAD

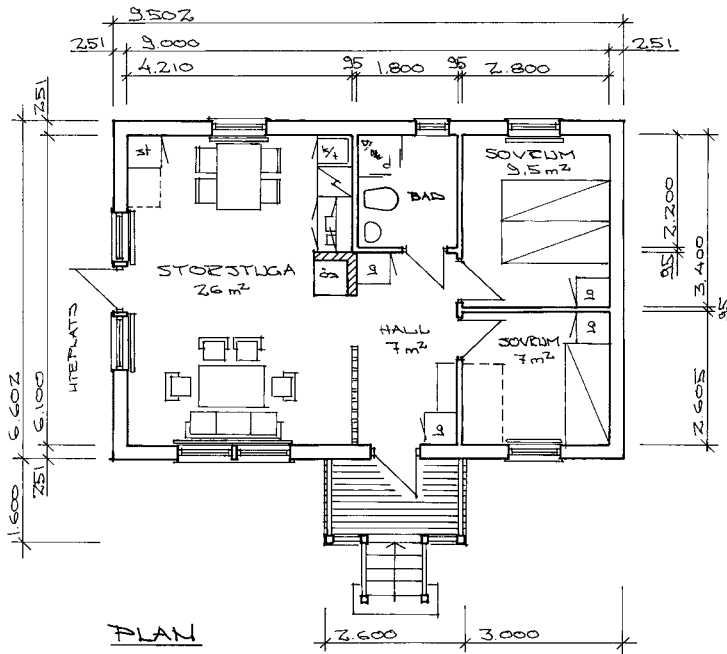

PLAN

PLINTAR
GRUNDLÄGGS
PÅ FROSTFRETT
DJUP

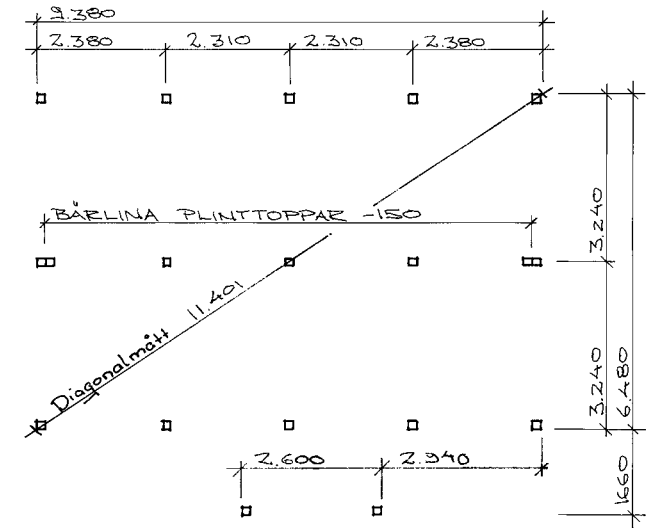

GRUNDPLAN



ENTREEFASAD

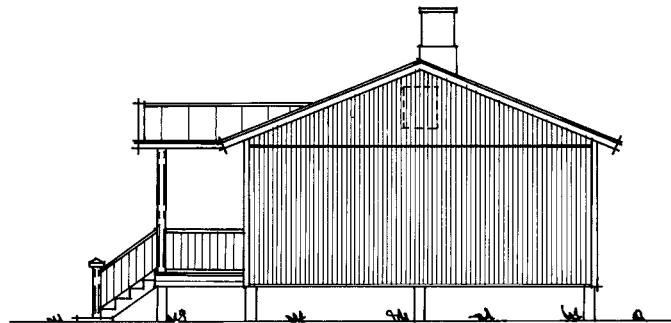

GAVELFASAD

LEVERANSALTERNATIV 2 VILLAISOLERING

FRITIDSHUS STORA JÖFALLET
PLAN, FASADER, BYA 63m²
SEKTION OCH
GRUNDPLAN

Ritad av Sixten Riström tel 0926-77721
Överkalik

30-09

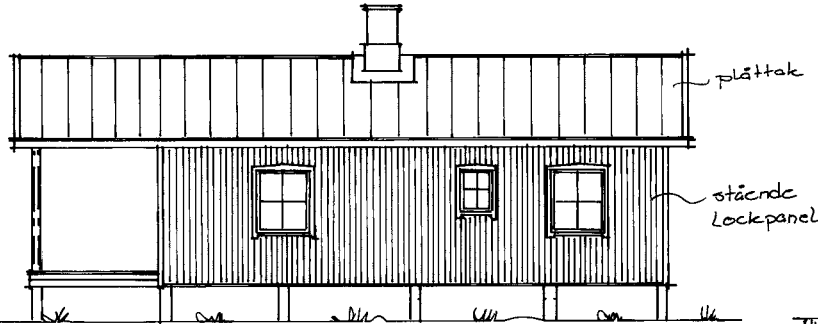

SIDOFASAD

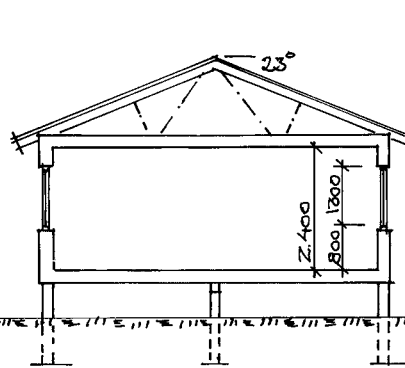

SEKTION

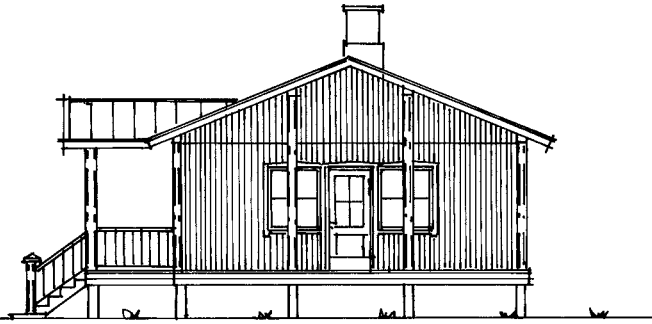

GÄVELFASAD

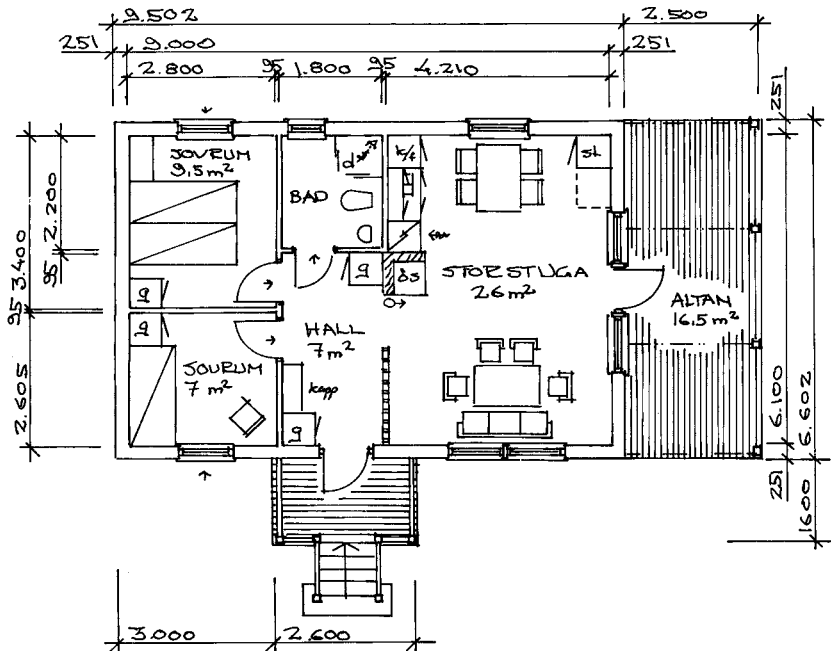

PLAN

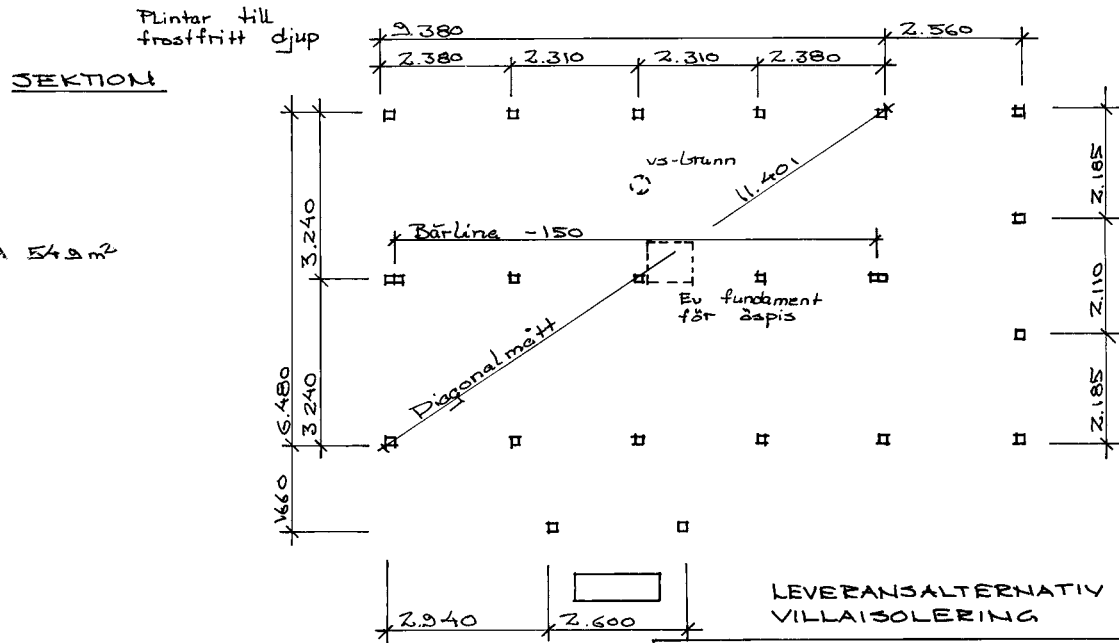

GRUNDPLAN

LEVERANSALTERNATIV 2
VILLAINSOLERING



ENTREFASAD

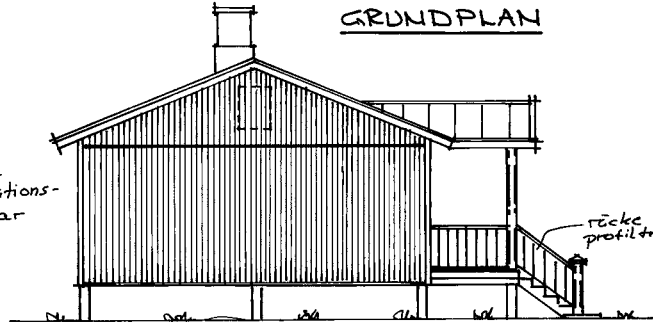

GÄVELFASAD

FRIIDSHUS STORA SJÖFALLET
 PLAN, FASADER,
 SEKTION OCH
 GRUNDPLAN
 BYA 63 m²
 ÖPP 21 m²
 Ritad av Sixten Ristrom tel 0926-77721
 Överkealix

30-10

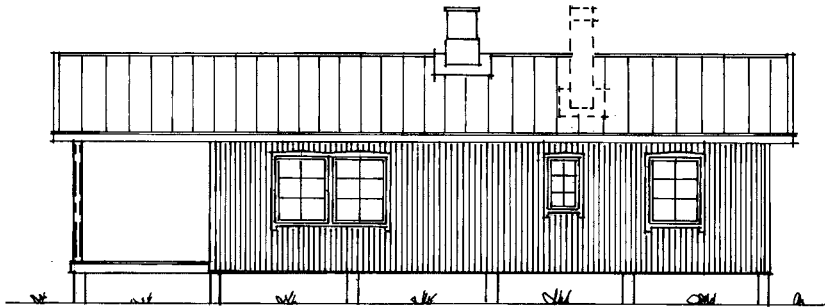

SIDOFAJAD

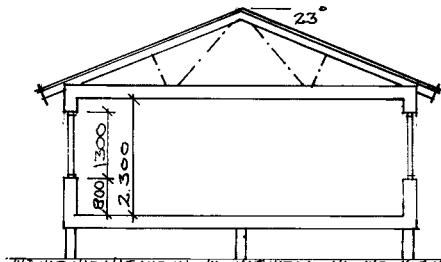

SEKTION

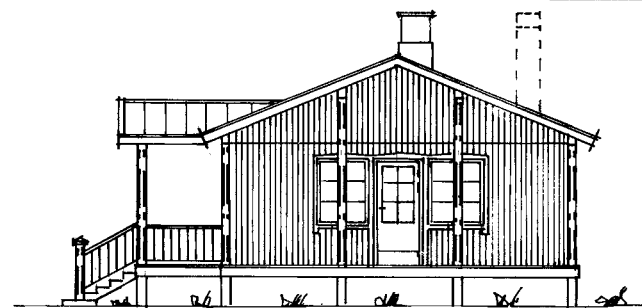

GAVELFAJAD

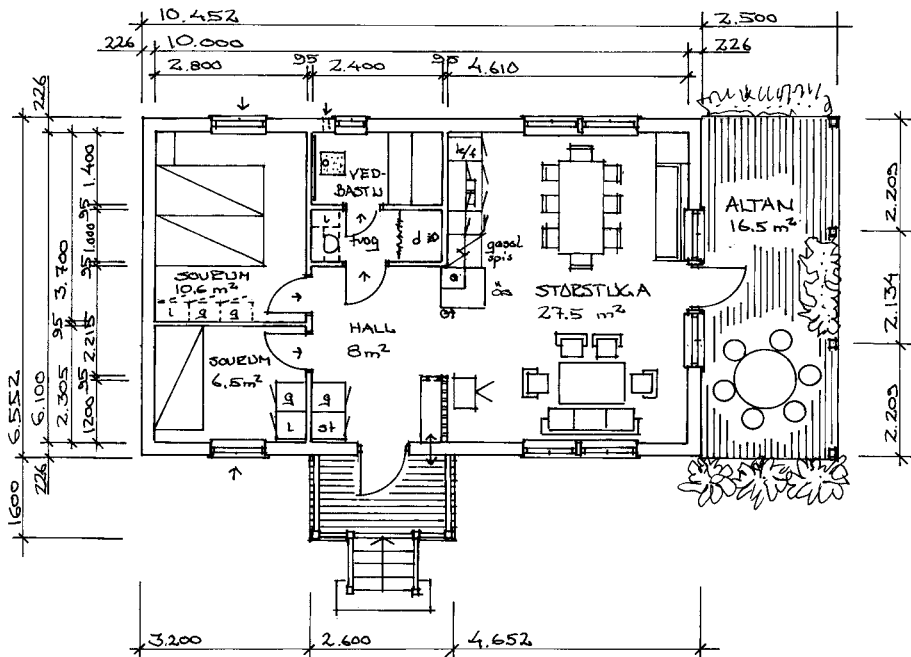

PLAN

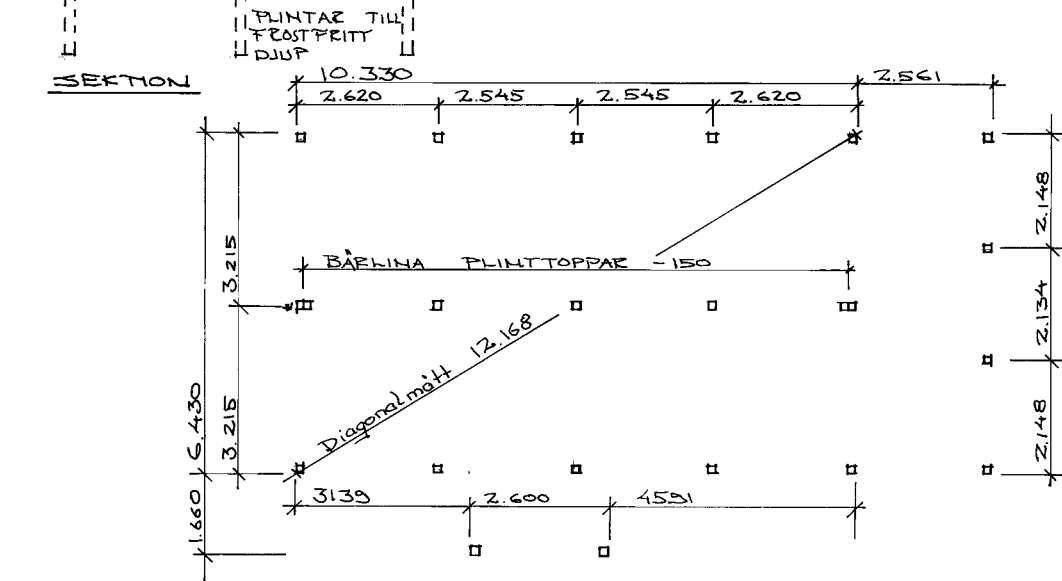

GRUNDFPLAN

LEVERANSALTERNATIV 1

FRITIDSHUS STORA SJÖFALLET

PLAN, FASADER, BYA 60 m²
SEKTION OCH ÖPPA 21 m²
GRUNDFPLAN

Ritad av Sixten Riström
Överkalix



ENTREFAJAD

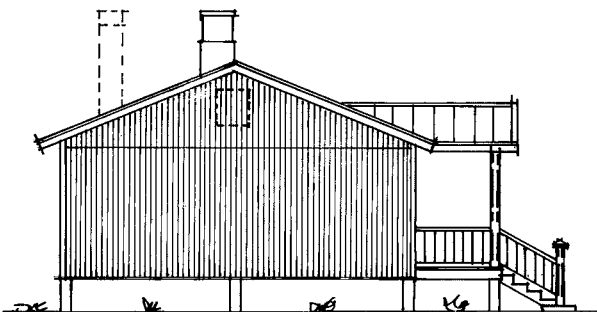

GAVELFAJAD

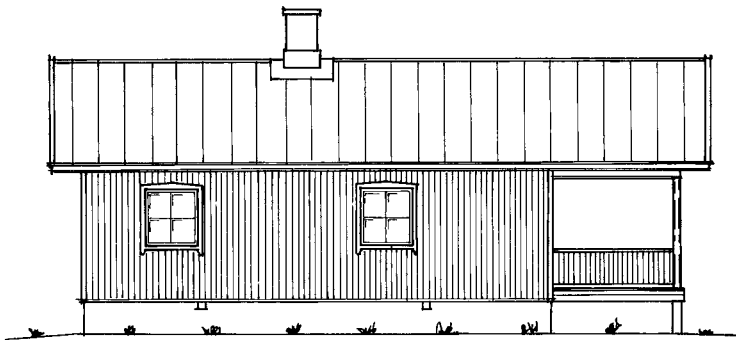

LÅNGFASAD

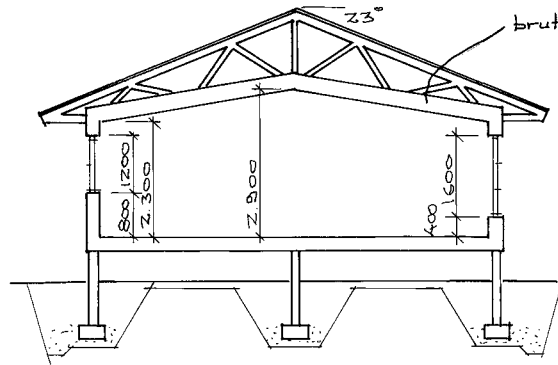

SEKTION

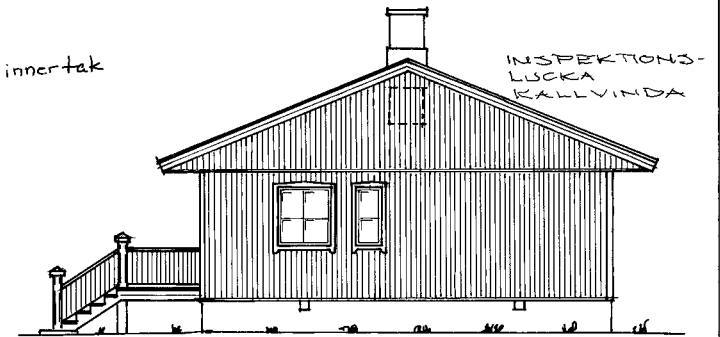

GAVELFASAD

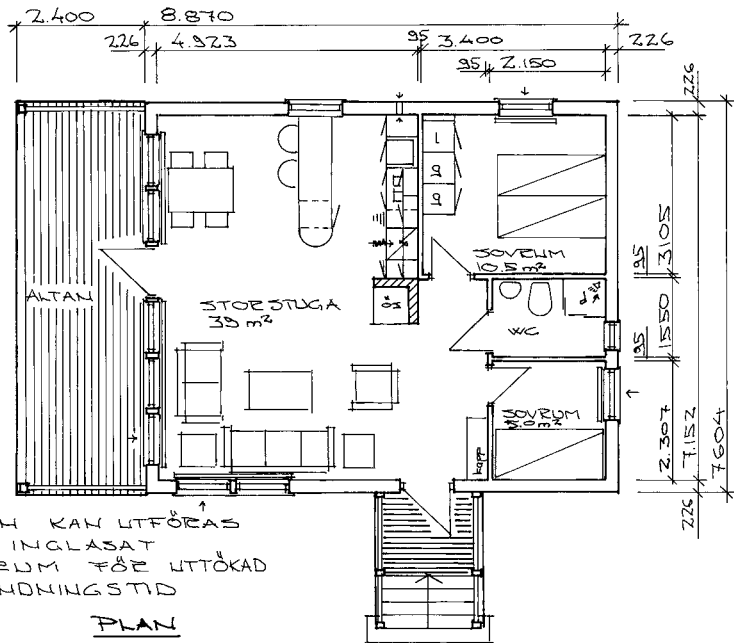

PLAN

ALTAN KAN UTFÖRAS SOM INGLASAT UTERUM FÖR UTÖKAD ANVÄNDNINGSTID

FÖNSTERSTORLEKAR KAN FÖRÄNDRAS FÖR UTÖKAT LUSINTAG.

HUSET KAN FÖRÄNDRAS FÖR BEHÅLLANDE AV BASTU TILL WC. INNERVÄGGAR KAN BEHÅLLAS AV MÖBLER. FRITIDSHUSET KAN FÖRLÄNGAS MED 1200 MODULLER.

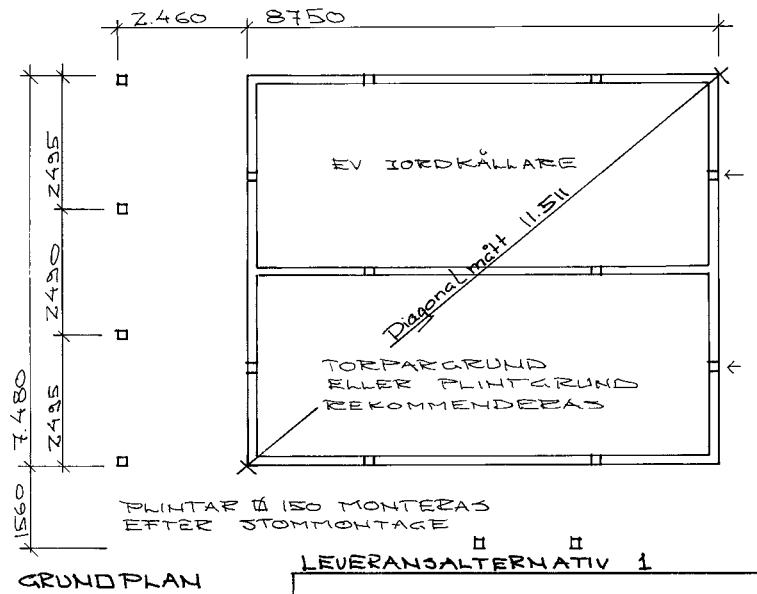

GRUNDPLAN

LEVERANSALTERNATIV 1

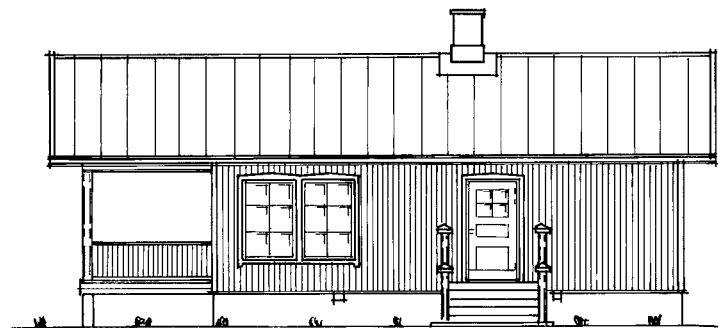

ENTREEFASAD

STÄHNDE LÖCKPANEL MED TÄCKRÄNDE FÖRDER

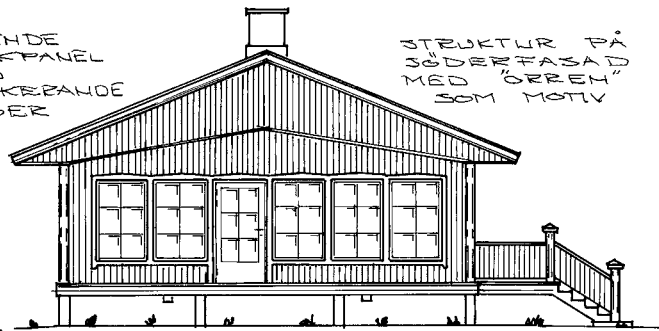

GAVELFASAD

FRITIDSHUS ORRFORSEN BYA 68 m²
PLAN, FASADER, ÖPA 19 m²

SEKTION OCH
GRUNDPLAN

Ritad av Sixten Riström tel 0926-77721
Överkalix

30-12

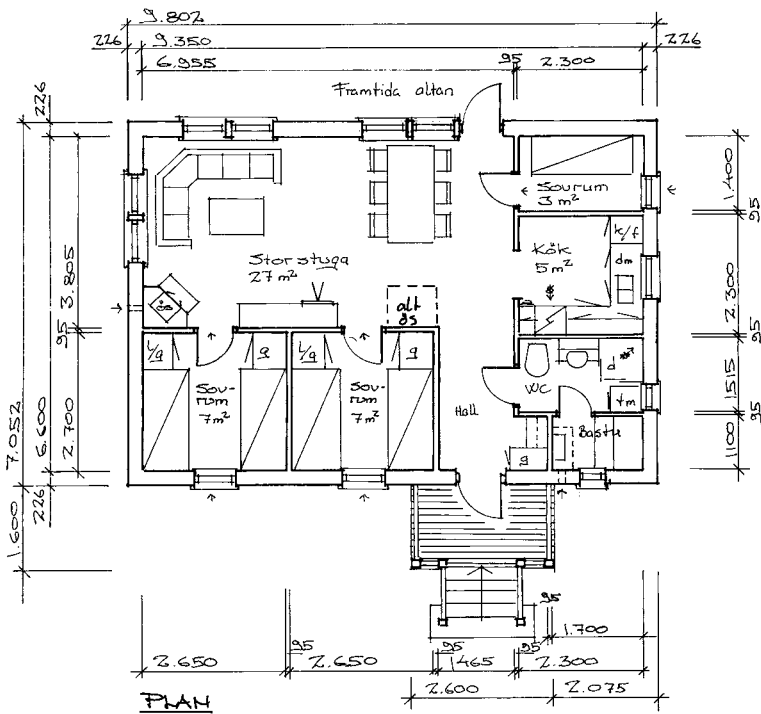
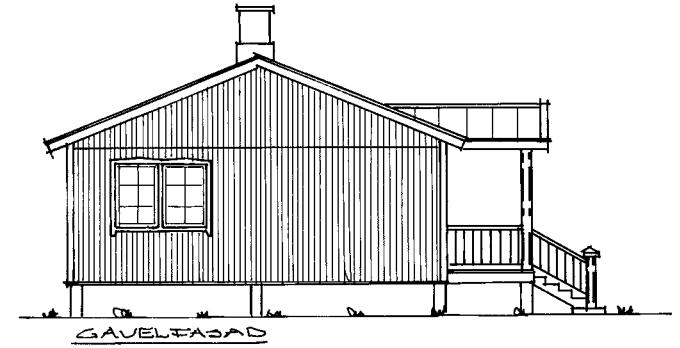
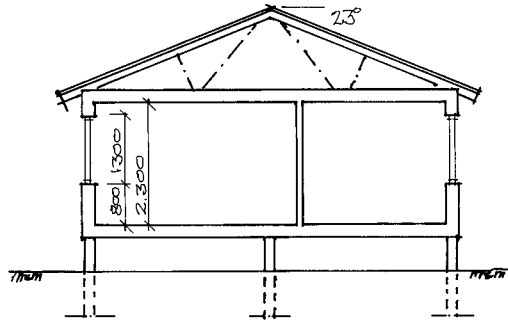
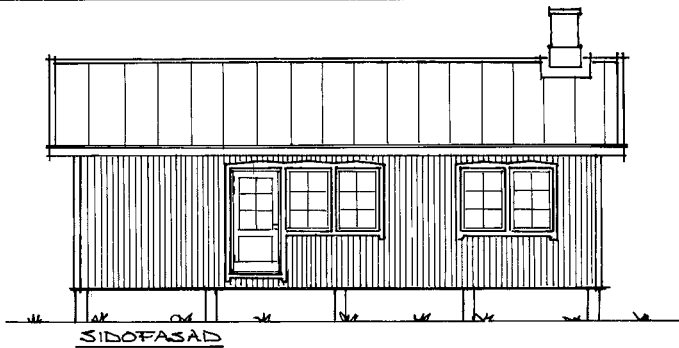

SEKTION

150 BTG-PLINTAR
TILL FROSTFRITT
DIUP

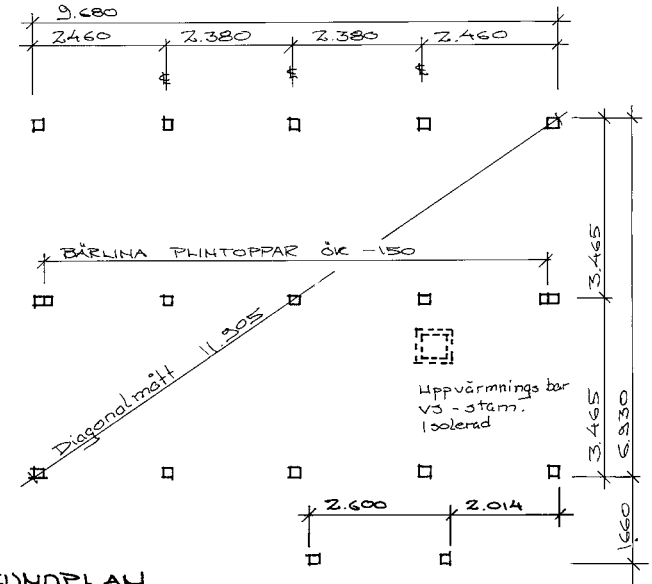

En extra
plint
murad
öppnings

Uppvärmnings bar
v3-stam.
isolerad

GRUNDPLAN

LEVERANSALTERNATIV 1

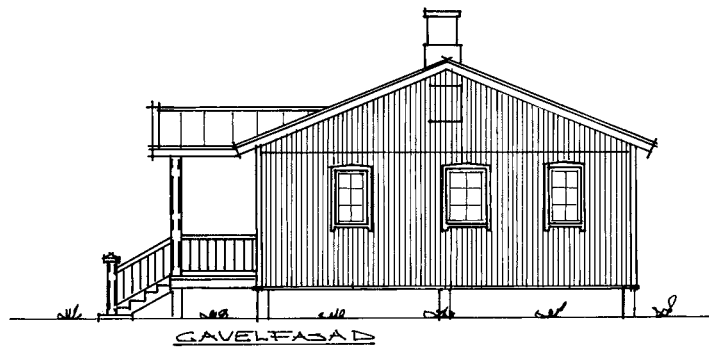

FRITIDSHUS STORFÖRSEN BYA 70m²
PLAN, FASADER,
SEKTION OCH
GRUNDPLAN

Ritad av Sixten Riström tel 0926-77721
Överkalix

30-13

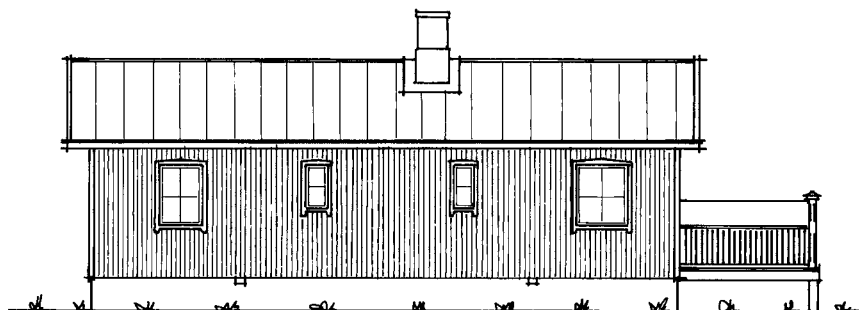

SIDOFASAD

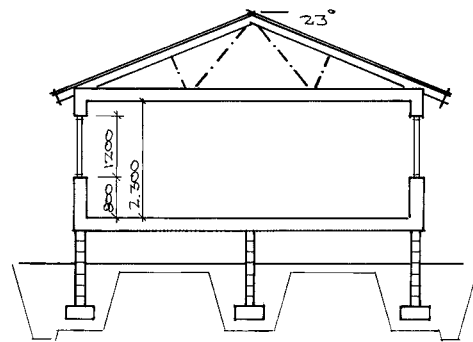

SEKTION

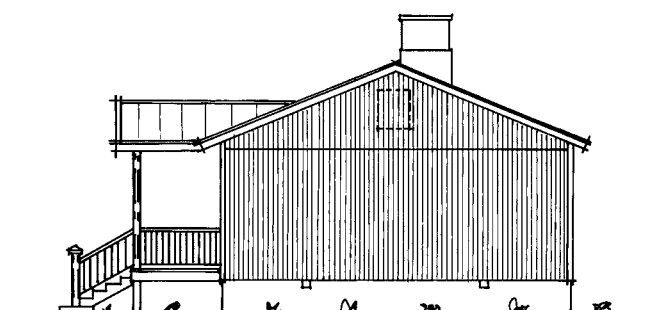

GÄVELFASAD

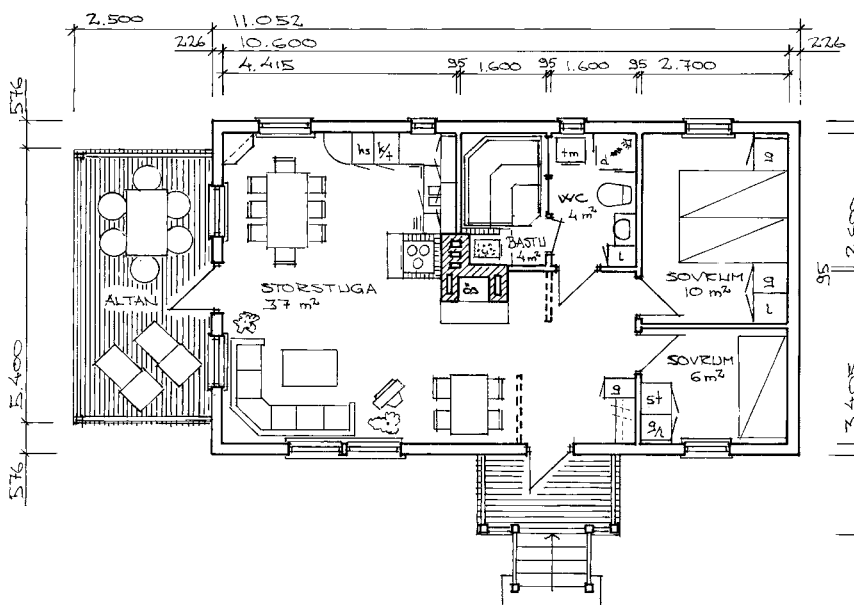

PLAN

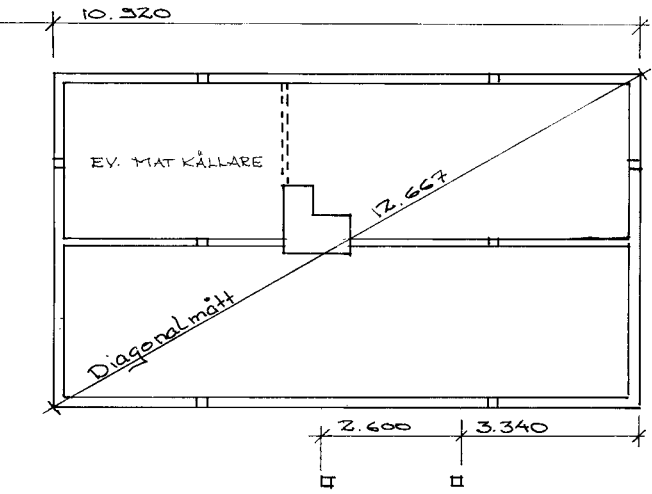
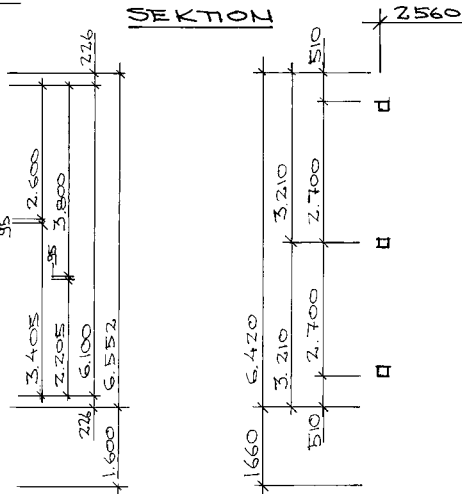

GRUNDPLAN

LEVERANSALTERNATIV 1



ENTREFASAD



GÄVELFASAD

FRITIDSHUS AKKATS BYA 73 m²
 PLAN, FASADER, SEKTION OCH
 GRUNDLÄGGNINGSPÅN.

Ritad av Sixten Riström tel 0926-77721
 Överkalix

30-14

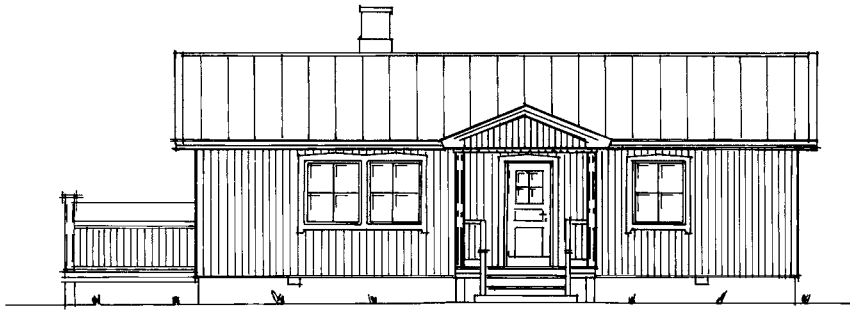

ENTREFFASAD

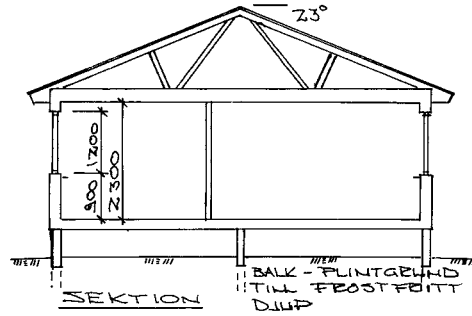

SEKTION

BALK - FLINTGÄLND
TILL FROSTFRI
DJUP

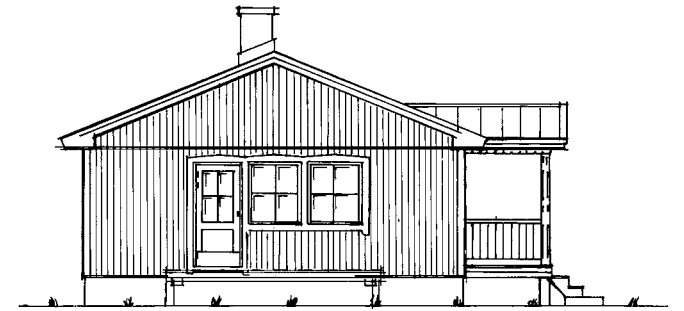

GAVELFASAD

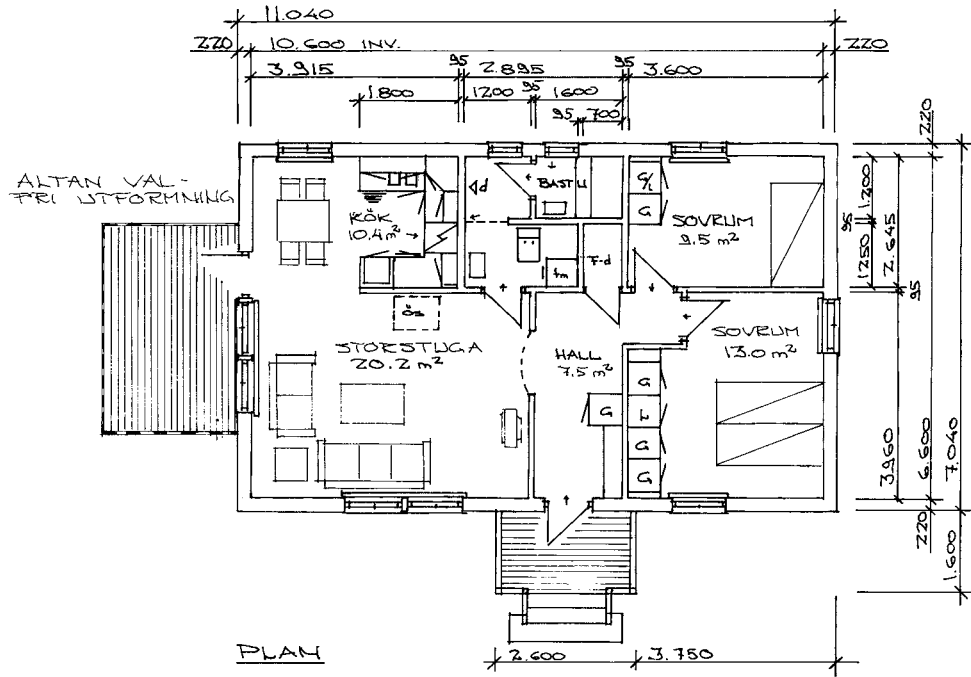

PLAN

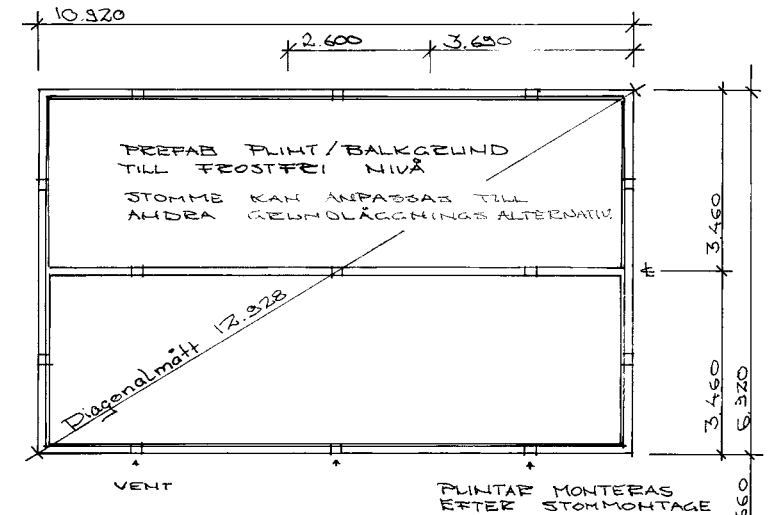

GRUNDPLAN

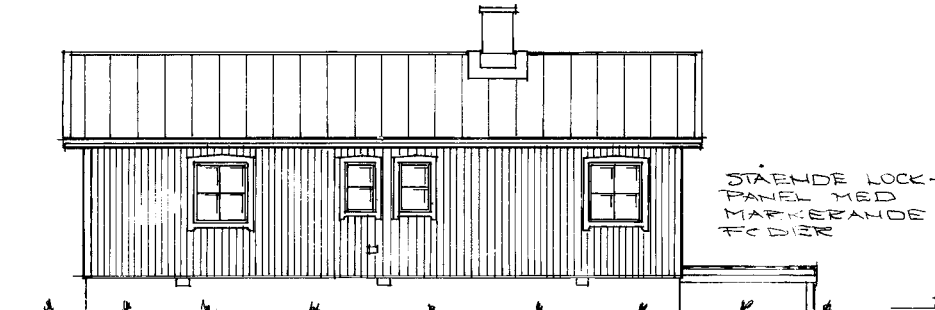

LÅNGFASAD

STÅENDE LOCK-
TÄVEL MED
TÄKTERALOR
FÖR DÖRR

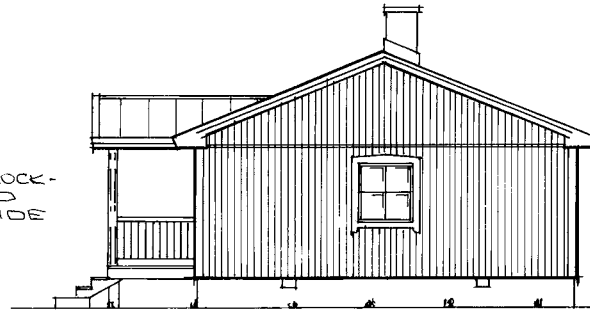

GAVELFASAD

LEVERANSALTERNATIV 1

FRITIDSHUS AKKATS BYA 77 m²

PLAN, FASADER OCH SEKTION
GRUNDPLAN

Skala 1:100

Ritad av Sixten Riström tel 0926-11721
Övertalix

30-15

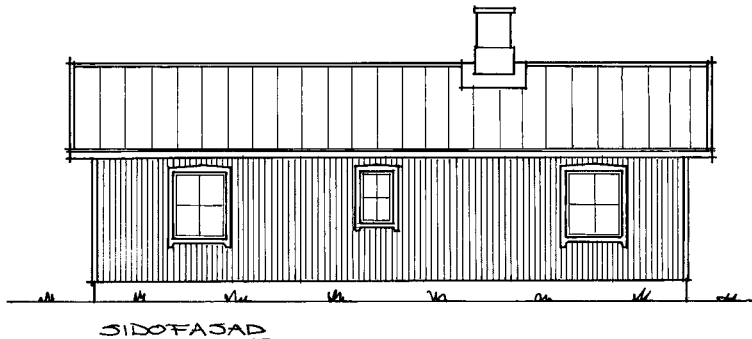

SIDOFA SAD

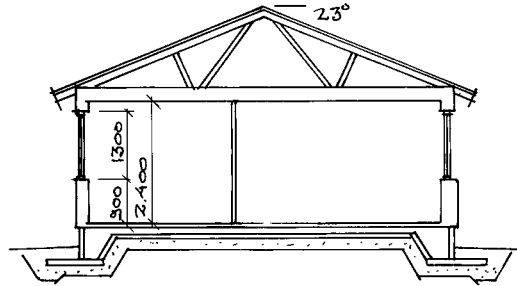

SEKTION

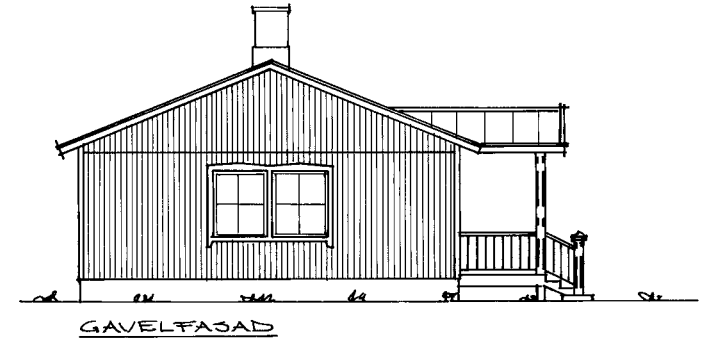

GAVELFA SAD

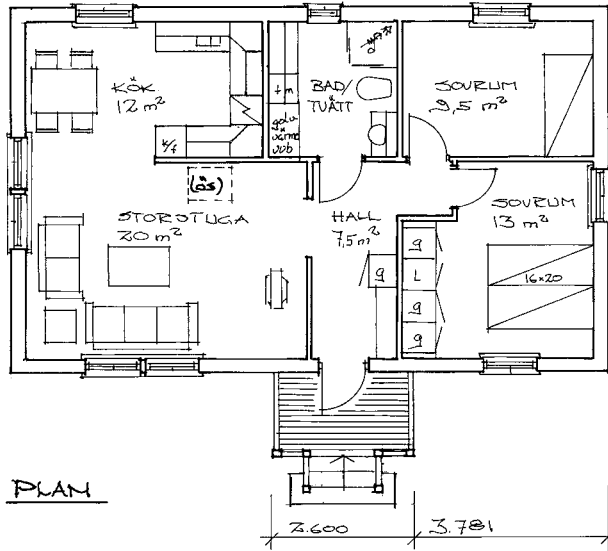
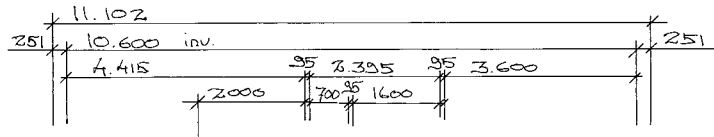

PLAN

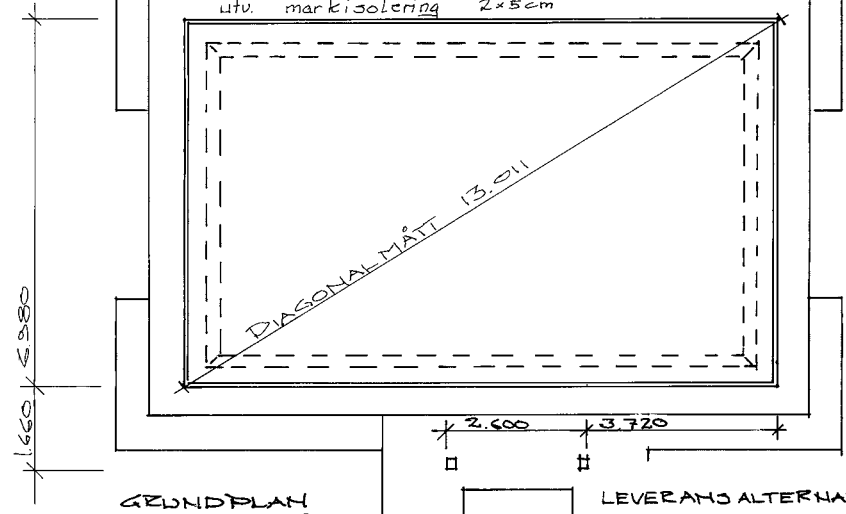
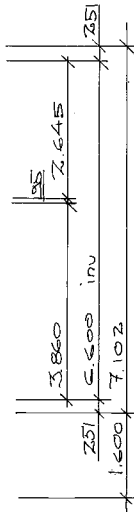

GRUNDPLAN

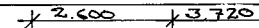

LEVERANS ALTERNATIV 2
VILLAISOLERING

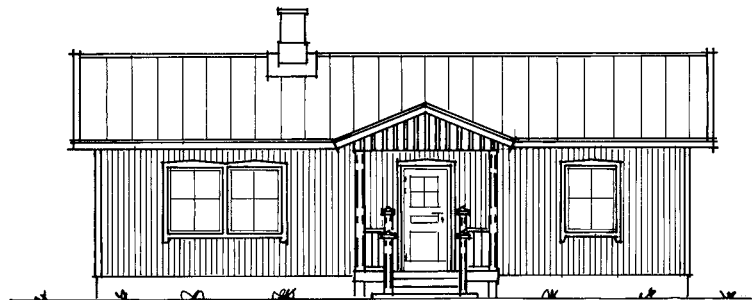

ENTREFA SAD

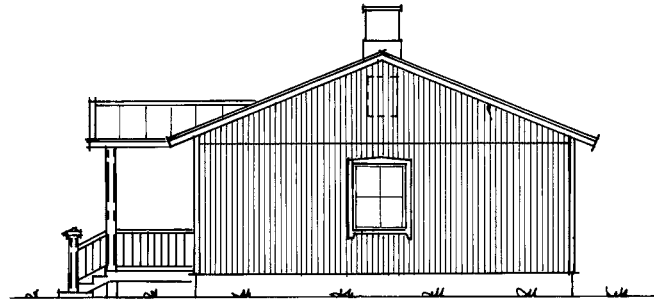

GAVELFA SAD

FRIDSHUS ARKATS BYA 79 m²

PLAN, FASADER, SEKTION
OCH GRUNDPLAN

Blau Sixten Riström tel 0926-77721

30-16

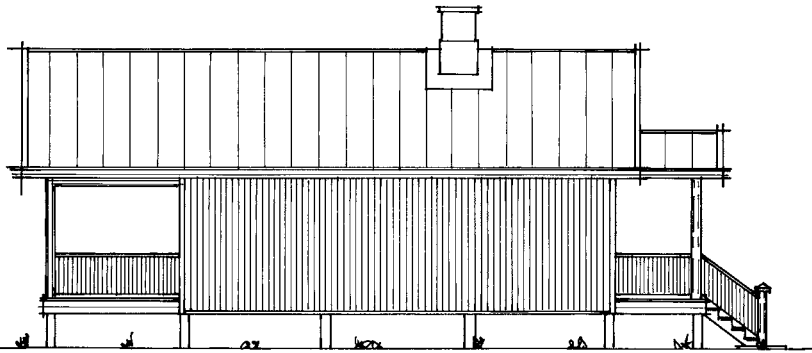

SIDOFASAD

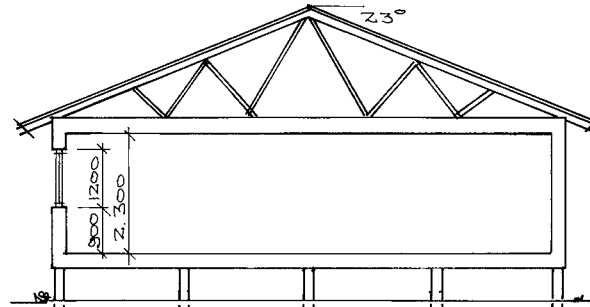

SEKTION

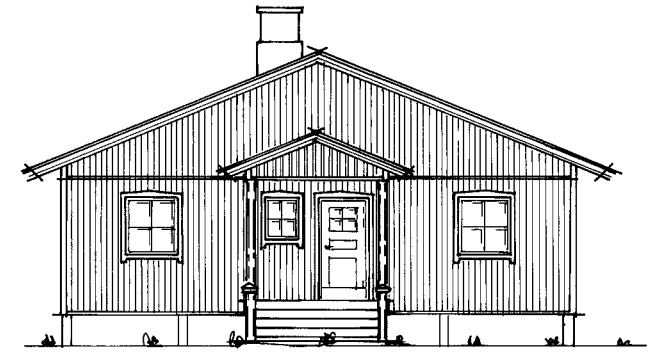

GAVELFASAD MED ENTRE

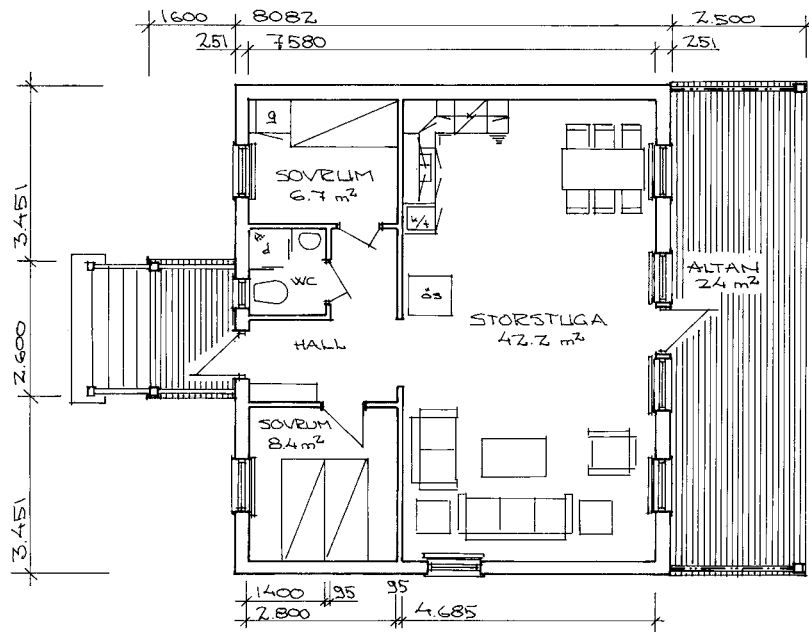

PLAN

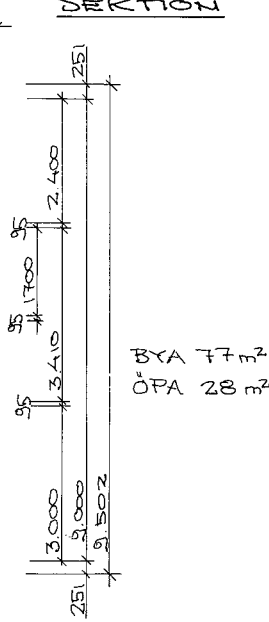

BYA 77 m²
ÖPA 28 m²

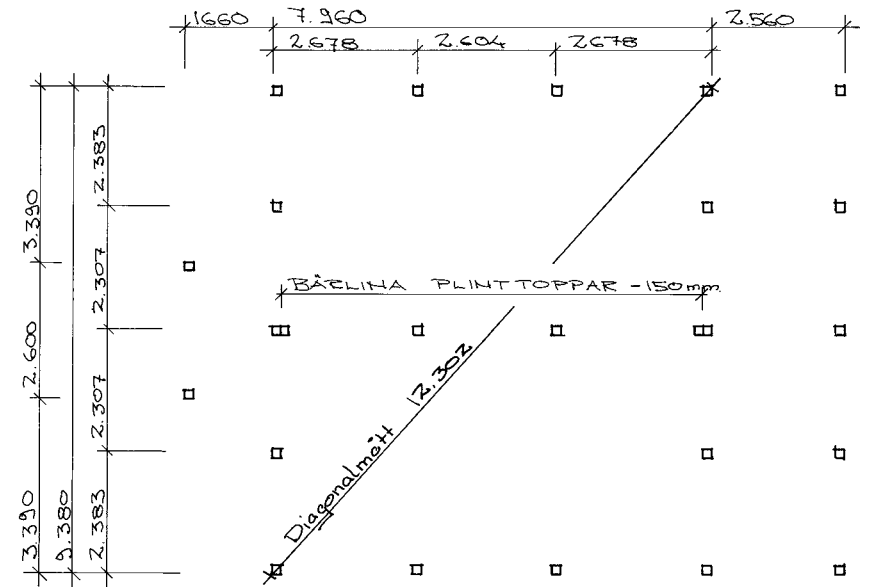

GRUNDPLAN

LEVERANSALTERNATIV 2 VILLAISOLERING

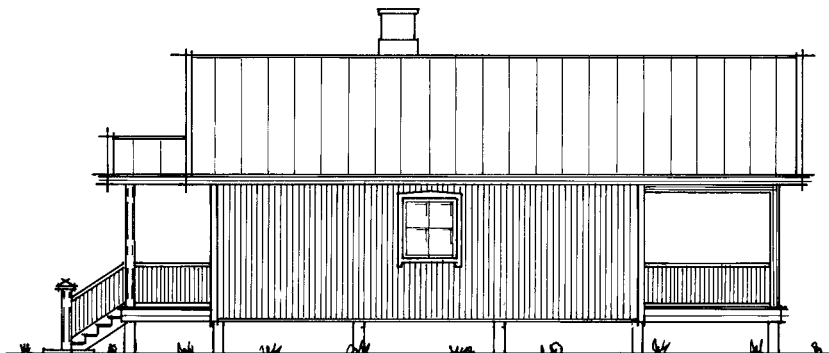

SIDOFASAD

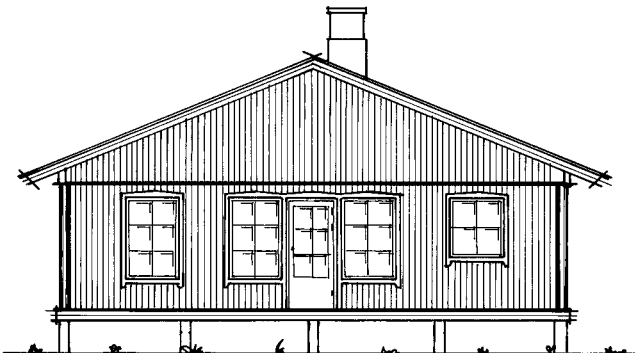

GAVELFASAD

FRITIDSHUS LAXFORSÉN BYA 77 m²
PLAN, FASADER, ÖPA 28 m²
SEKTION OCH
GRUNDPLAN

Ritad av Sixten Riström tel 0926-77721
Överkalix

30-17

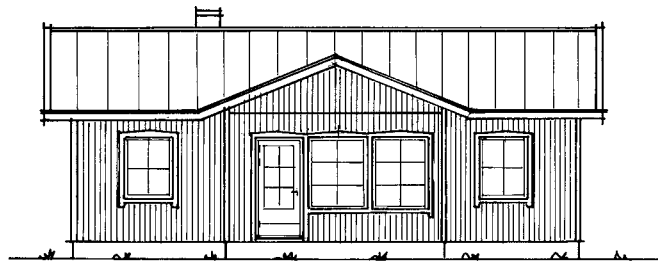

SIDOPASAD

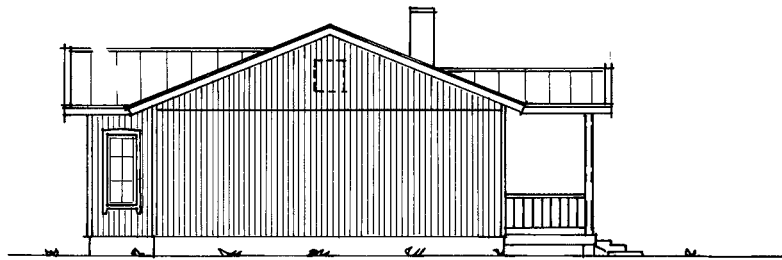

GAVELFASAD

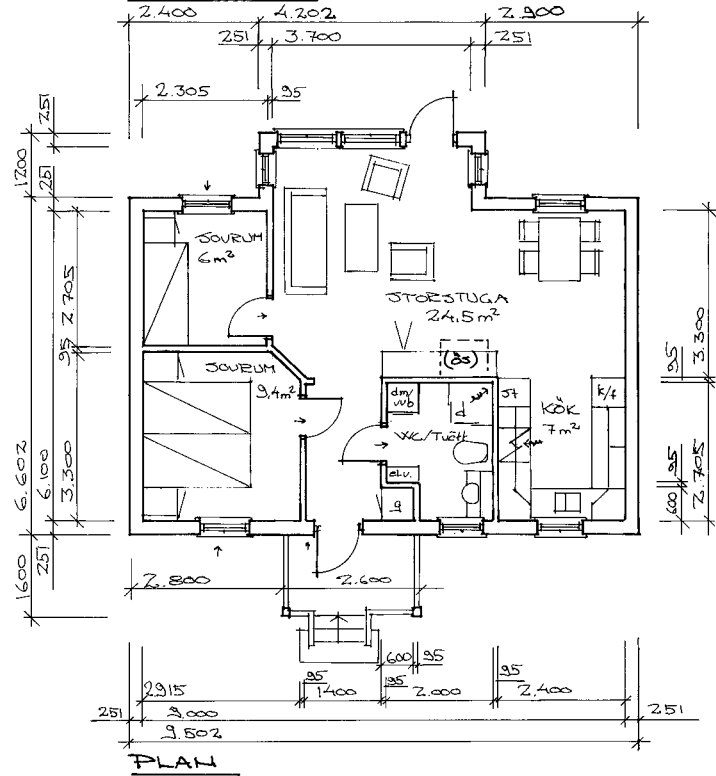

PLAN

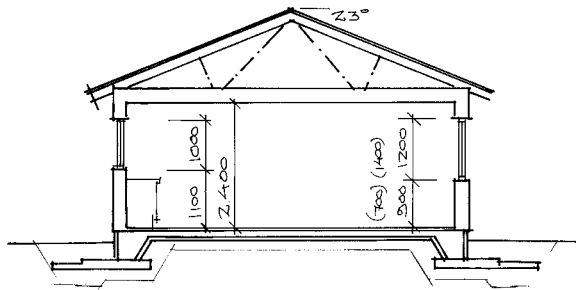

SEKTION

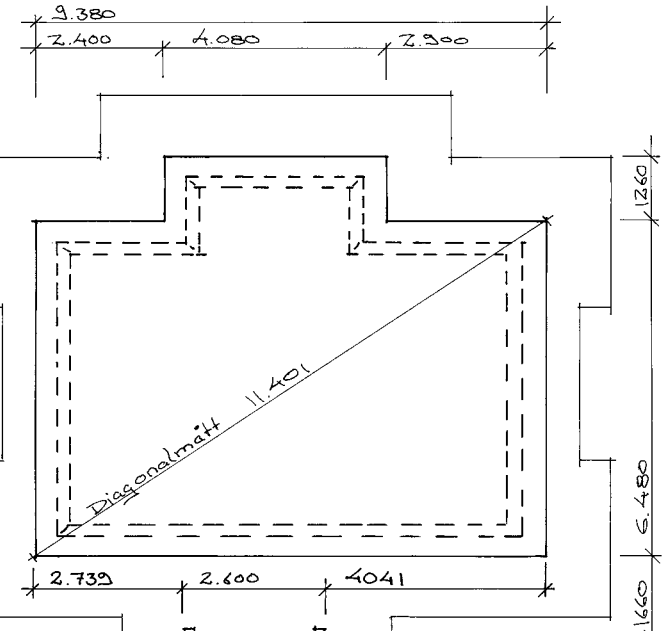

GRUNDPLAN

LEVERANSALTERNATIV Z
VILLAISOLERING



ENTREPASAD

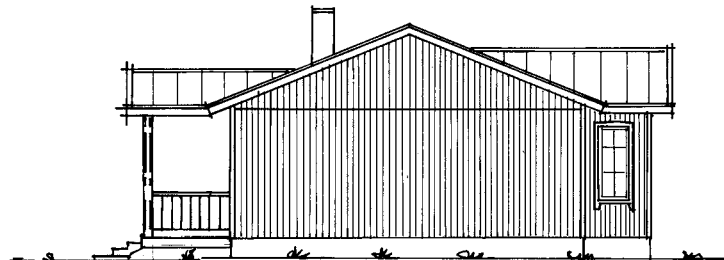

GAVELFASAD

FRITIDSHUS RENTORSEN BYA 68m²
PLAN, FASADER, SEKTION OCH
GRUNDPLAN

Ritad av Sixten Riström tel 0926-77721
Överkalix

30-18

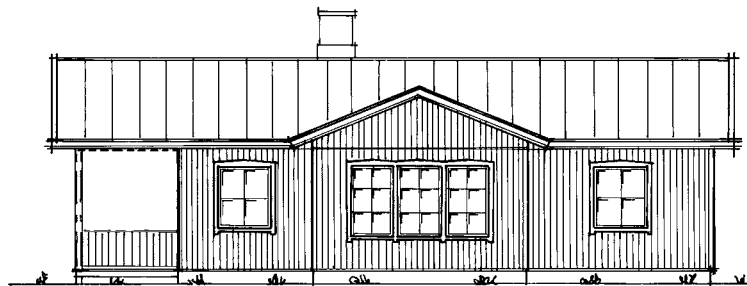

LÅNGFASAD

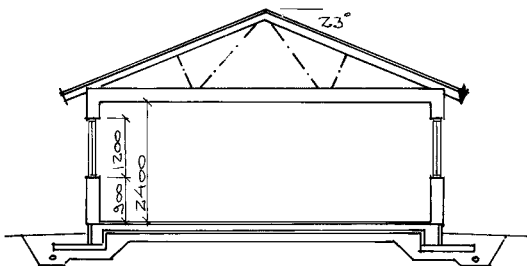
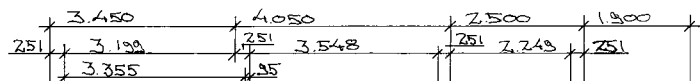

SEKTION

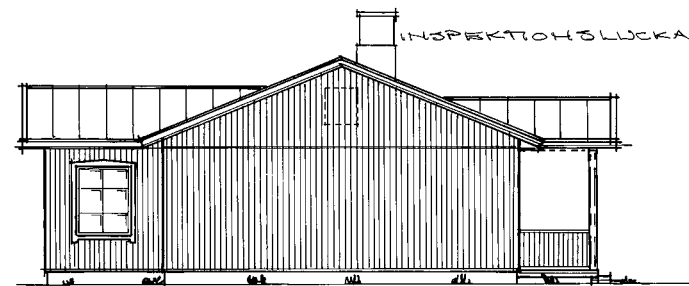

GÅVELFASAD

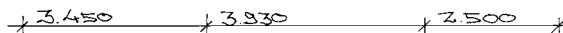

STÅENDE
 LOCKPANEL
 MED FODER-
 MARKERING

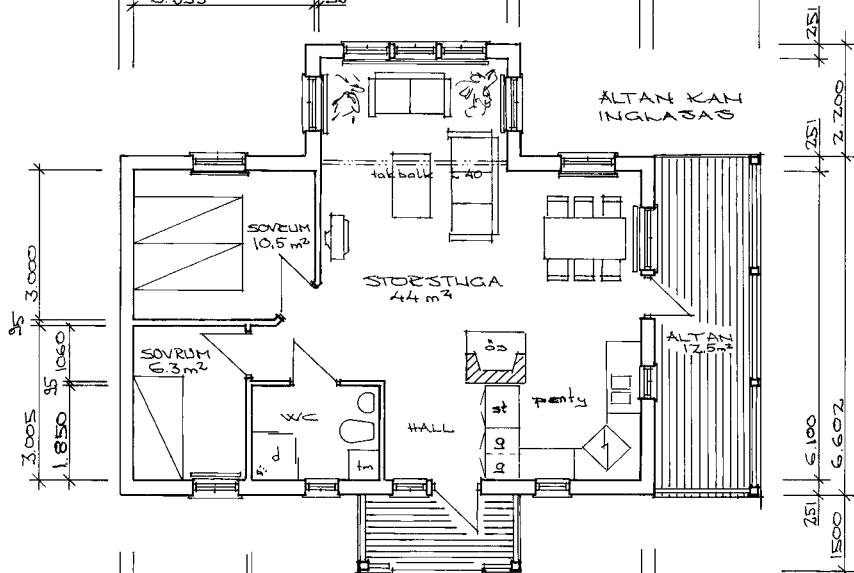

FRANKÖSNING
 KAN FÖRÄNDRAS
 ELLIGT
 DIKEMÅL
 BOA 64 m²
 BYA 77 m²
 ÖPA 17 m²

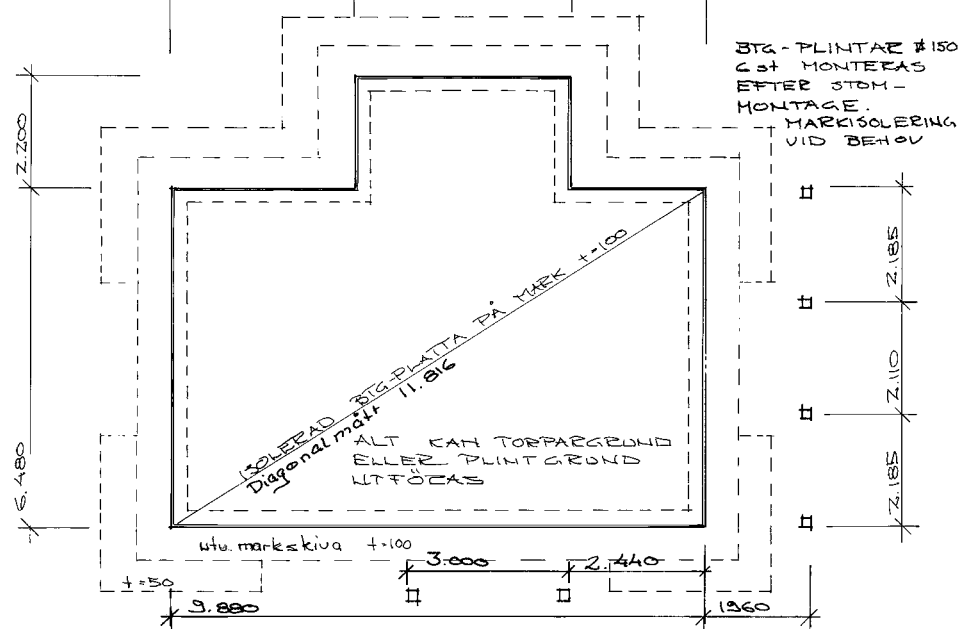

BTG-PLINTAR #150
 Går MONTERAS
 EFTER STOM-
 MONTAGE.
 MARKISOLERING
 VID BEHOV

LEVERANSALTERNATIV 2 VILLASOLERING

FRITIDSHUS RENTORSEN BYA 77 m²
 ÖPA 17 m²
 PLAN, FASADER,
 SEKTION OCH
 GRUNDPLAN

Ritad av Sixten Riström tel 0926-11721
 Överkalix

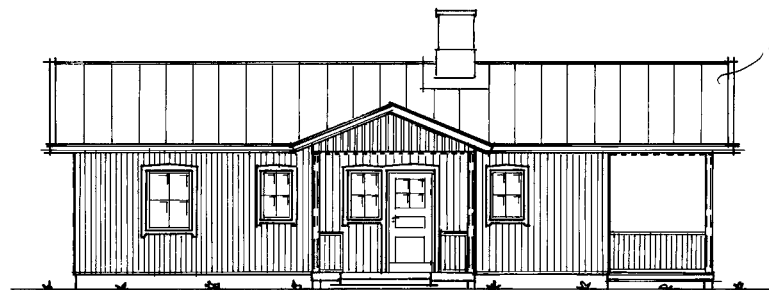

ENTREFFASAD

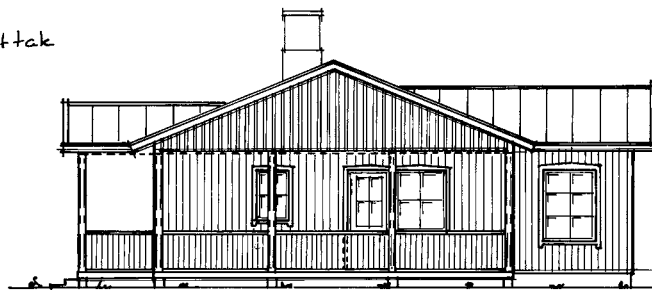

GÅVELFASAD

30-19

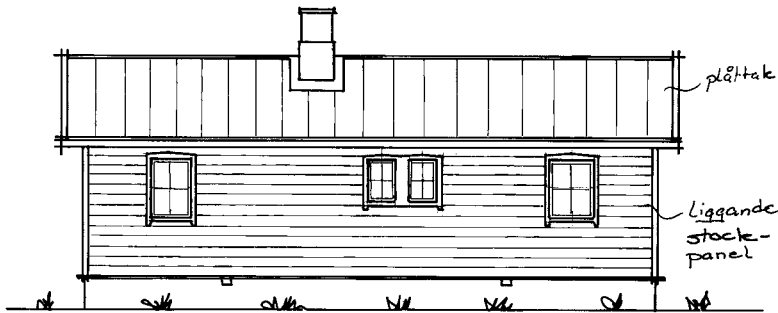

SIDOFASAD

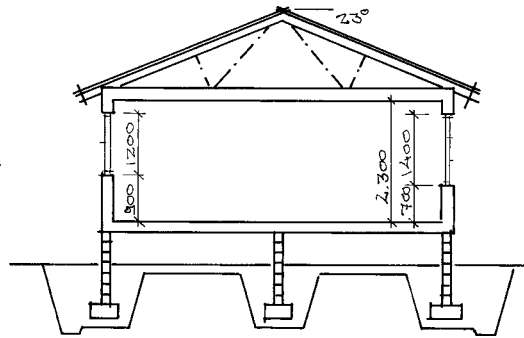

SEKTION



GAVELFASAD

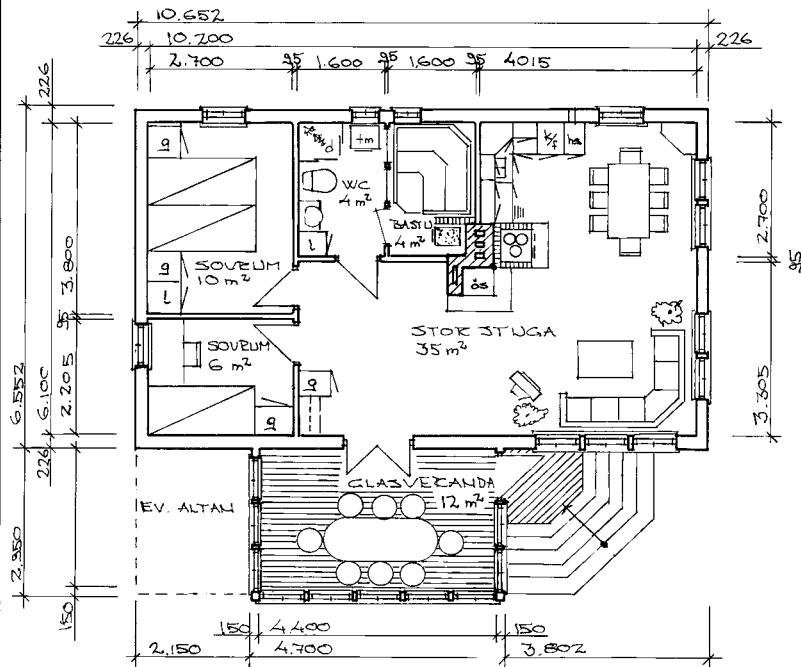

PLAN

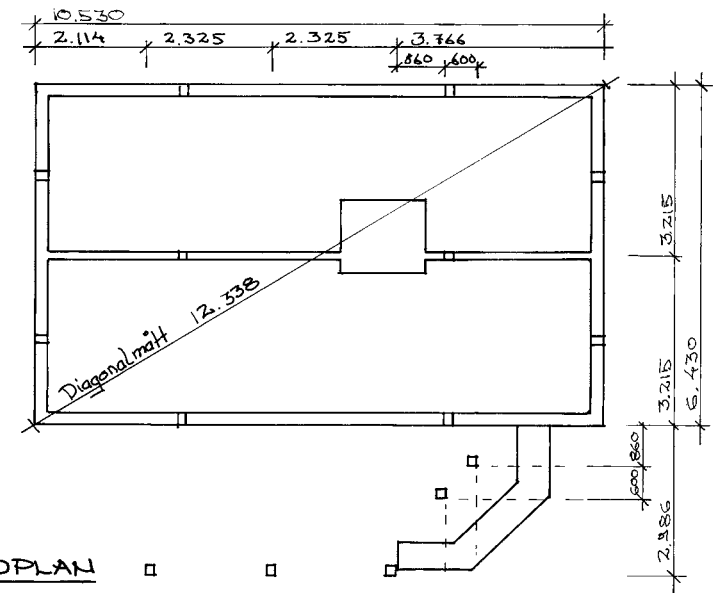

GRUNDPLAN

LEVERANSALTERNATIV 1



ENTREFA SAD



GAVELFASAD

FRITIDSHUS RENTORSEN BÅ 84 m²
 PLAN, FASADER, SEKTION OCH
 GRUNDLÄGGNINGSPÅN

Ritad av Sixten Riström tel 0926-77721
 Överkalix

30-20

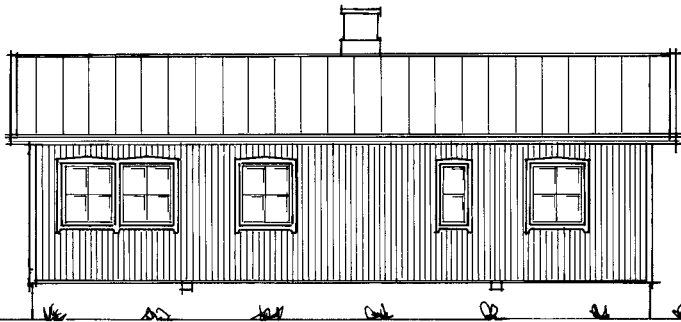

LÅNGFASAD

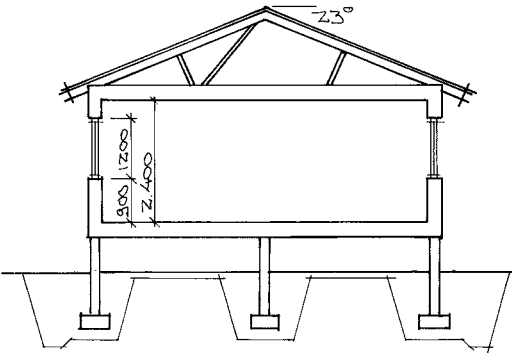

SEKTION

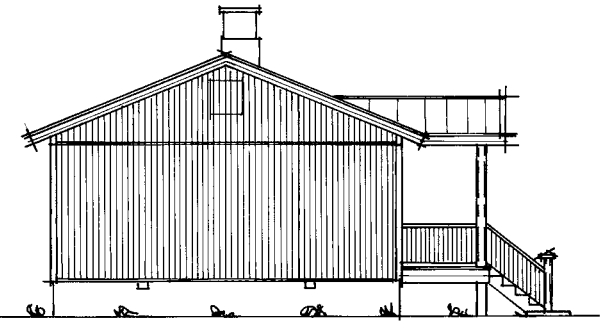

GAVELFASAD

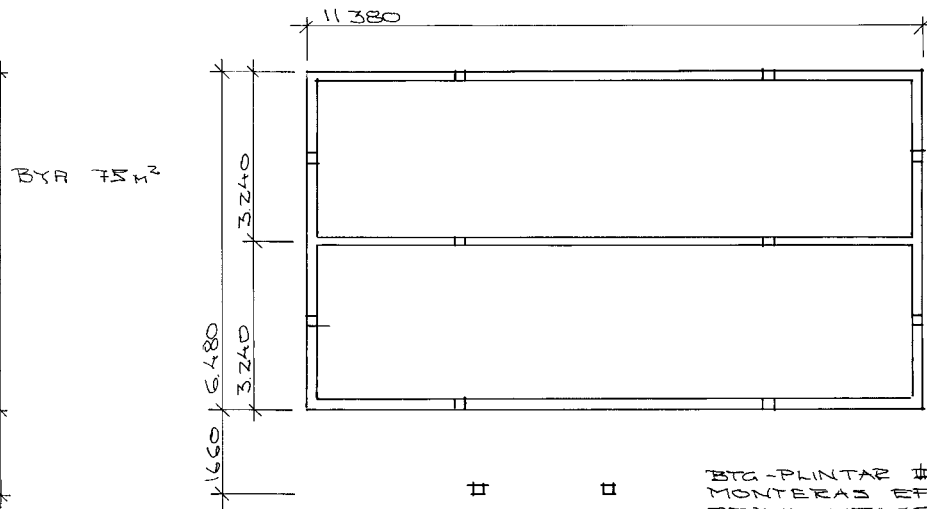
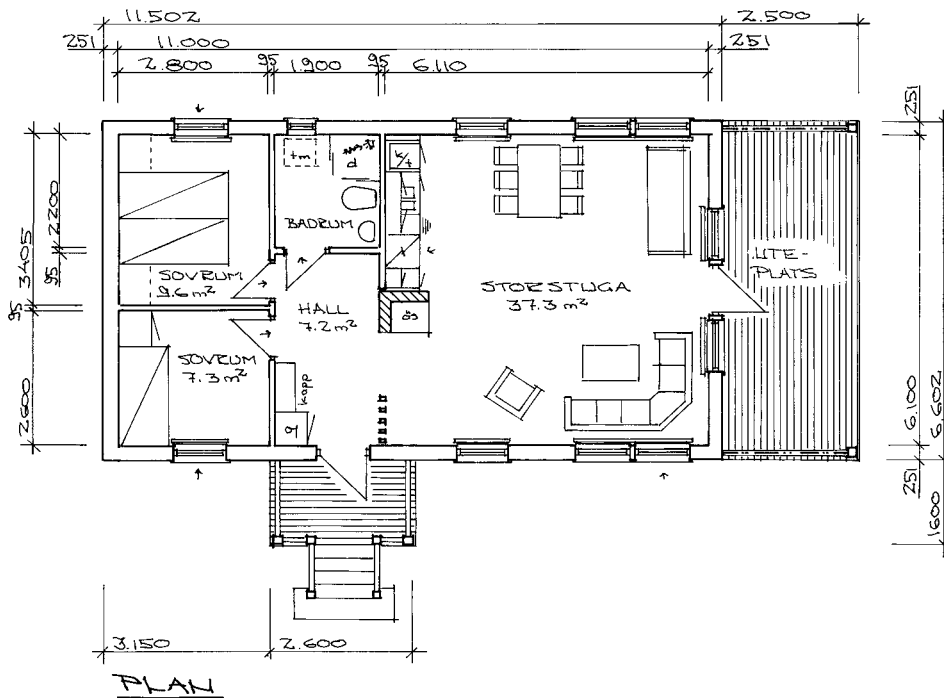

BTG-PLINTAR # 150
MONTERAS EFTER
STOMMONTAGE

LEVERANSALTERNATIV 2
VILLASISOLERING



ENTREFASAD

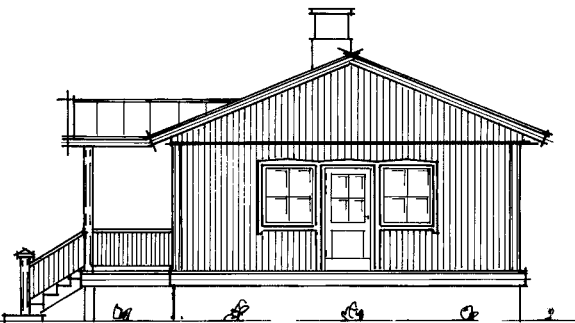

GAVELFASAD

FRITIDSHUS BRUDFORSEN BYA 75m²
PLAN, FASADER, SEKTION,
GRUNDLÄGGNINGSPÅN

Ritad av Sixten Ristrom tel 0926-77721
Överkalix

30-21

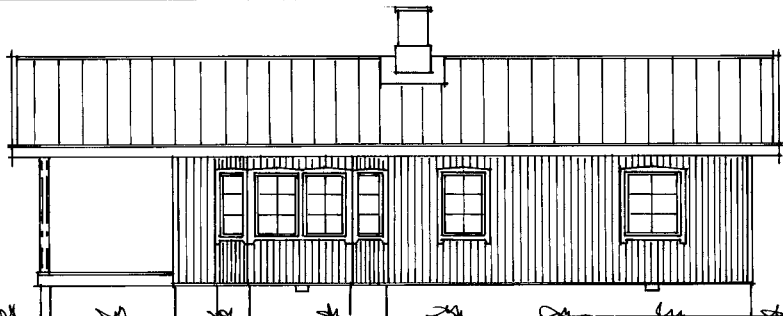

SIDOFAJAD

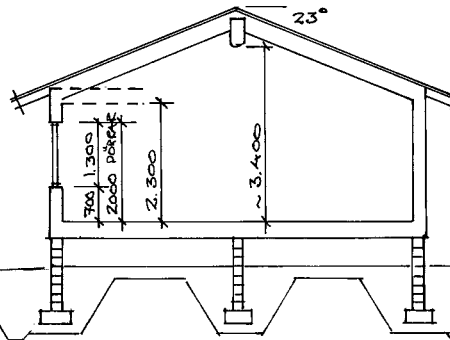

SEKTION

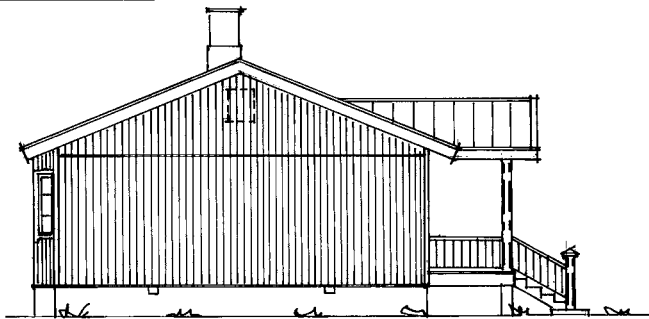

GAVELFAJAD

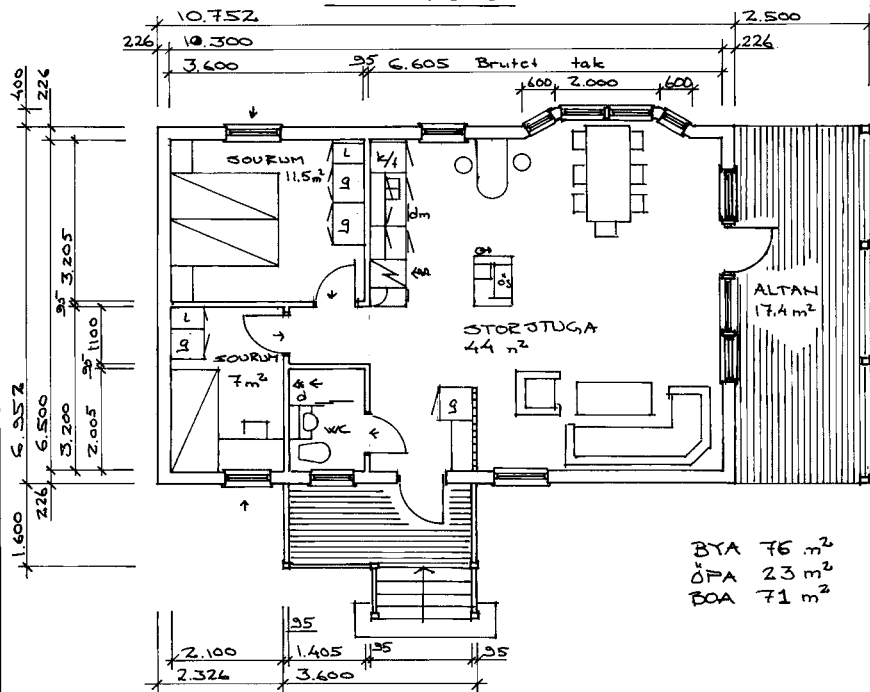

PLAN

BYA 76 m²
 ÖFA 23 m²
 BOA 71 m²

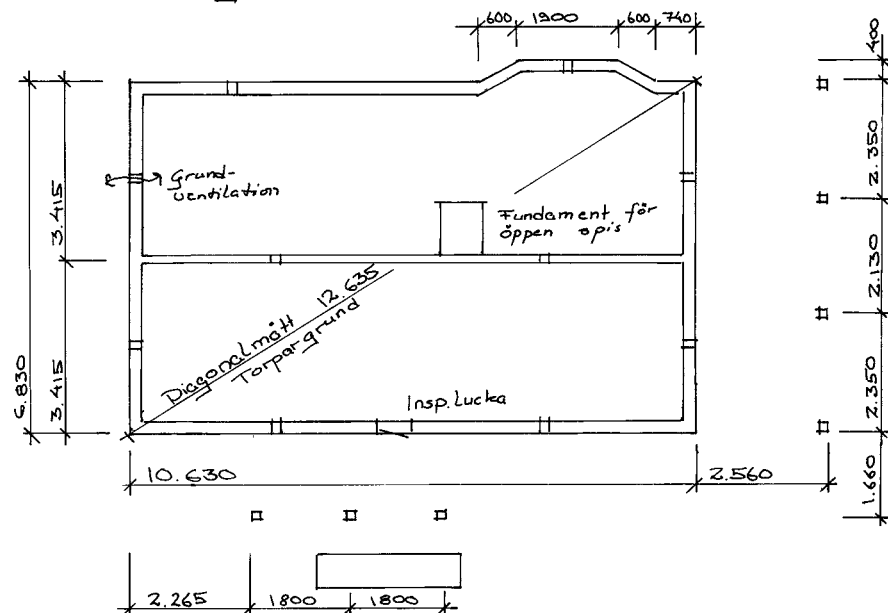

GRUNDPAN

LEVERANSVILLKOR 1



ENTREFAJAD



GAVELFAJAD

FRITIDSHUS ÄNGÅSAN BYA 76 m²
 PLAN, FASADER, ÖFA 23 m²
 SEKTION OCH GRUNDPAN
 Ritad av Sixten Riström tel 0926-77721
 Överkalix

30-22

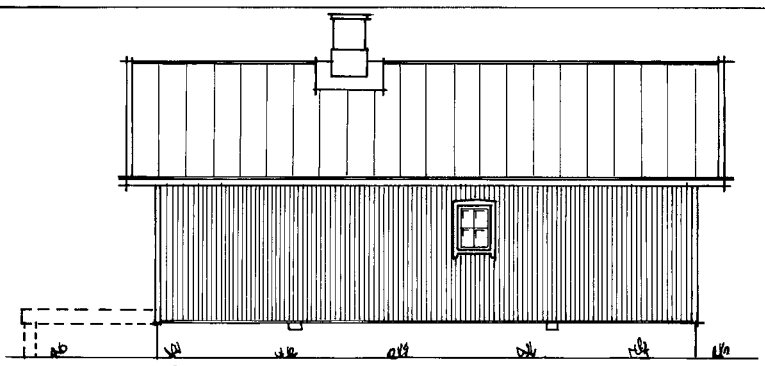

LÅNGFASAD

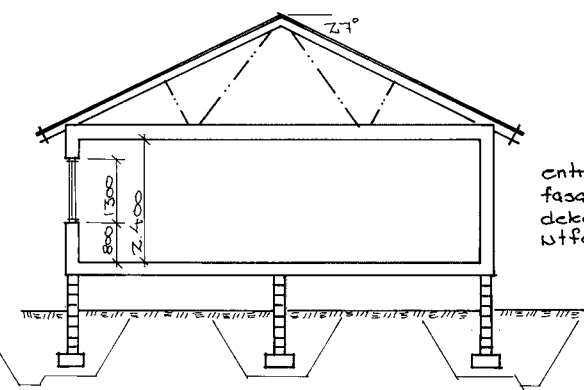

SEKTION

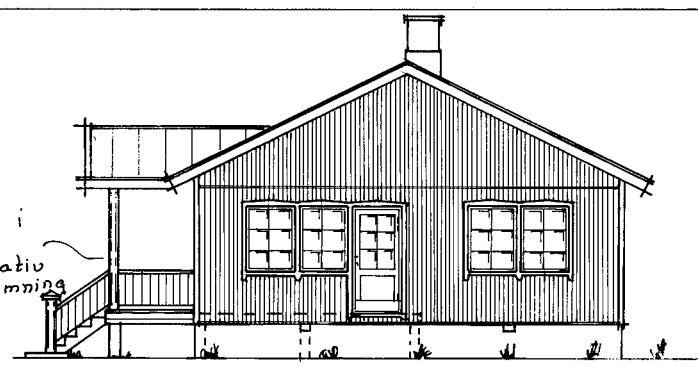

GAVELFASAD

entré i fasad dekorativ utformning

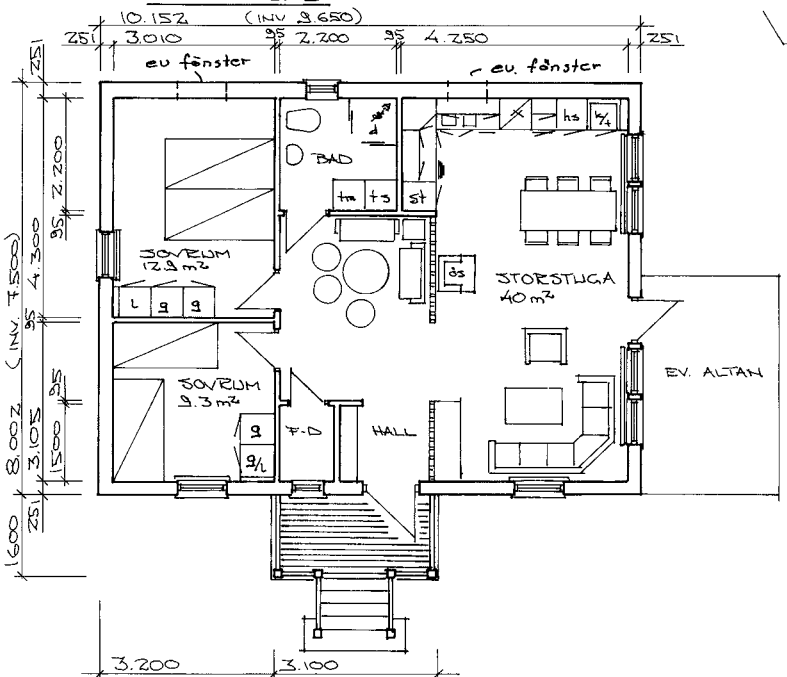

PLAN

BYA 81.32
BOA 72.4 m²
GFA 51.32

köksinredning medger andra dispositioner

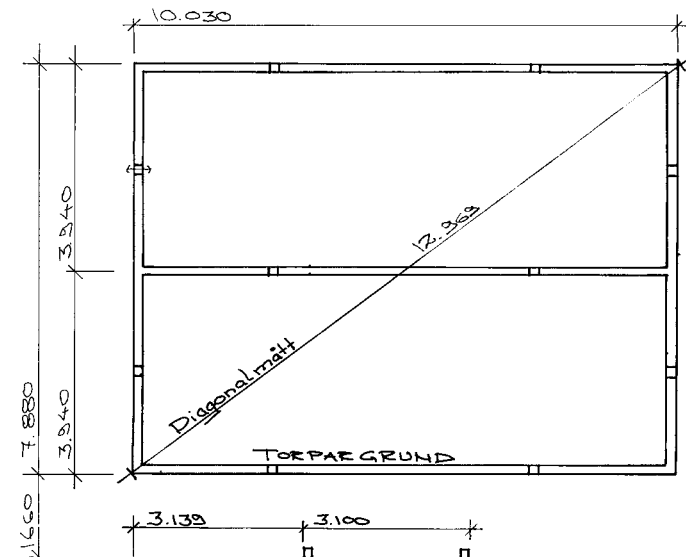

GRUNDPLAN

LEVEFANSALTERNATIV 2 VILLAISOLERING

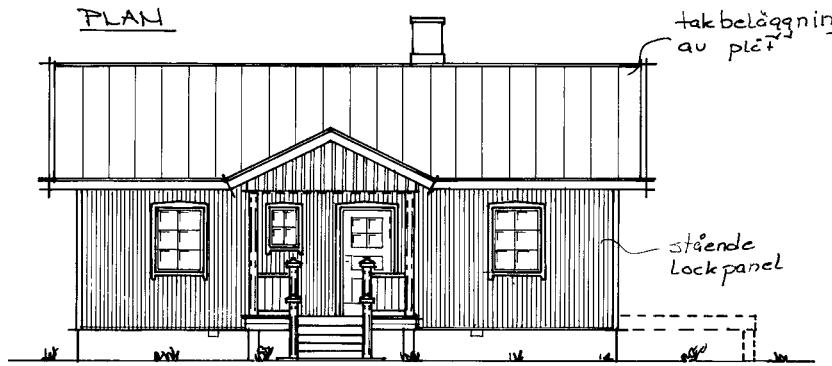

ENTREFASAD

takbeläggning av plåt

stående lockpanel

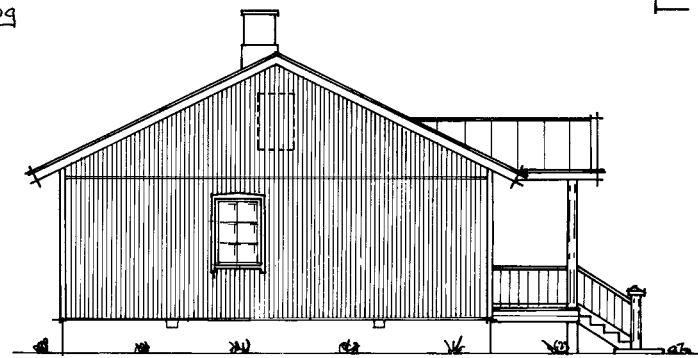

GAVELFASAD

FRITIDSHUS FÄLLFORSEN BYA 81 m²
PLAN, FASADER,
SEKTION OCH
GRUNDPLAN

Ritad av Sixten Riström tel 0926-77721
Överkalix

30-23

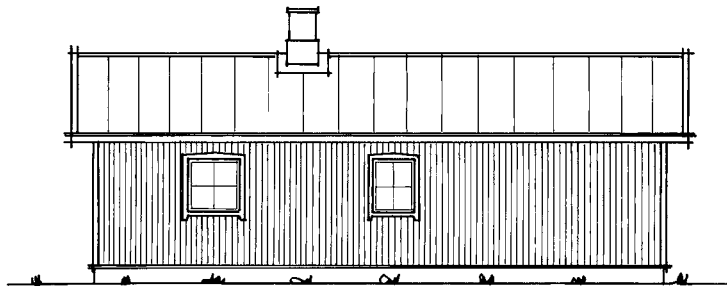

SIDOFASAD

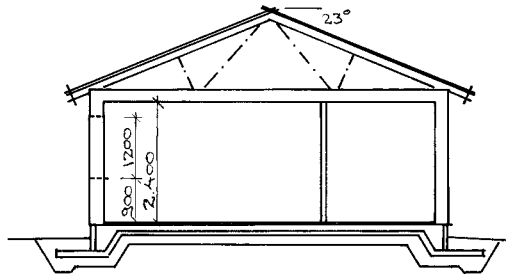

SEKTION

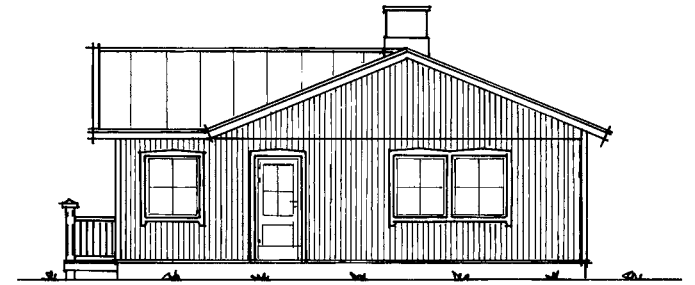

GAVELFASAD

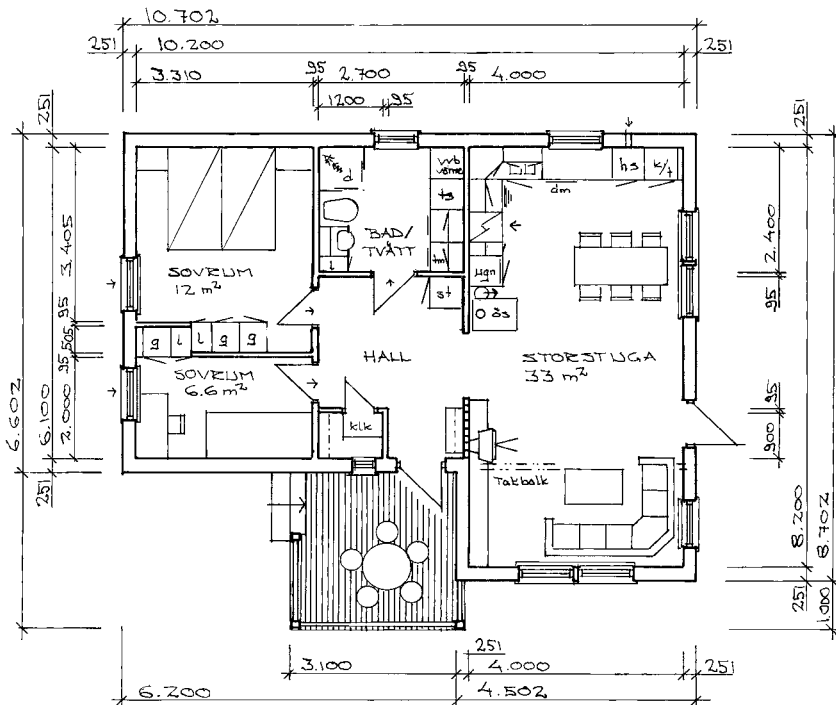

PLAN

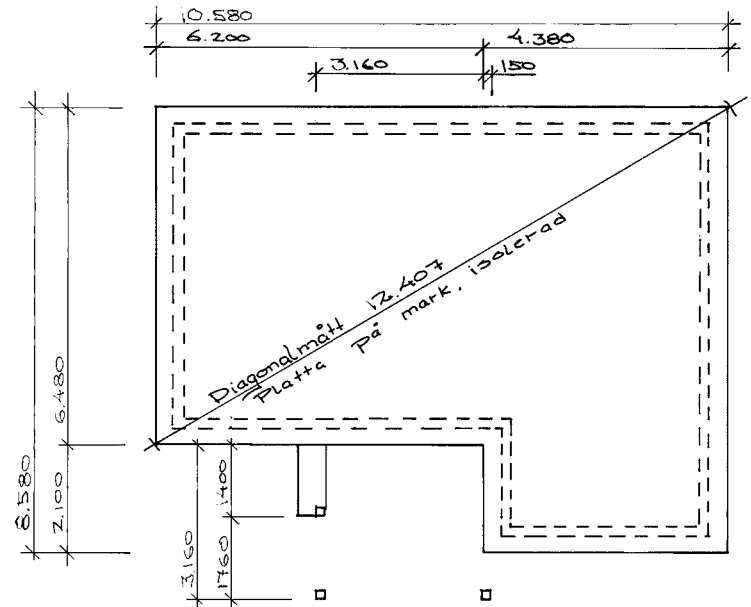

GRUNDPLAN

LEVERANSALTERNATIV 2 VILLAISOLERING

FRITIDSHUS HARSPRÄNGET BIA 73 m²

PLAN, FASADER, SEKTION OCH GRUNDLÄGGNINGSPLAN.

Ritad av Sixten Riström tel 0926-77721
Överkalix

30-24



ENTREFASAD



GAVELFASAD

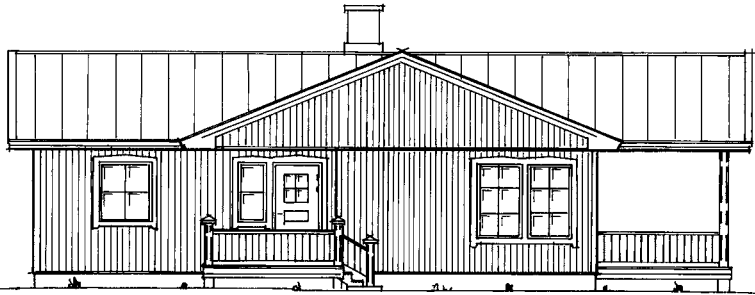

ENTRÉFASAD

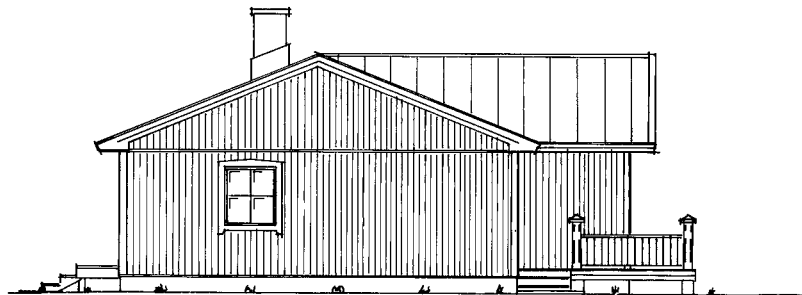

GAVELFASAD

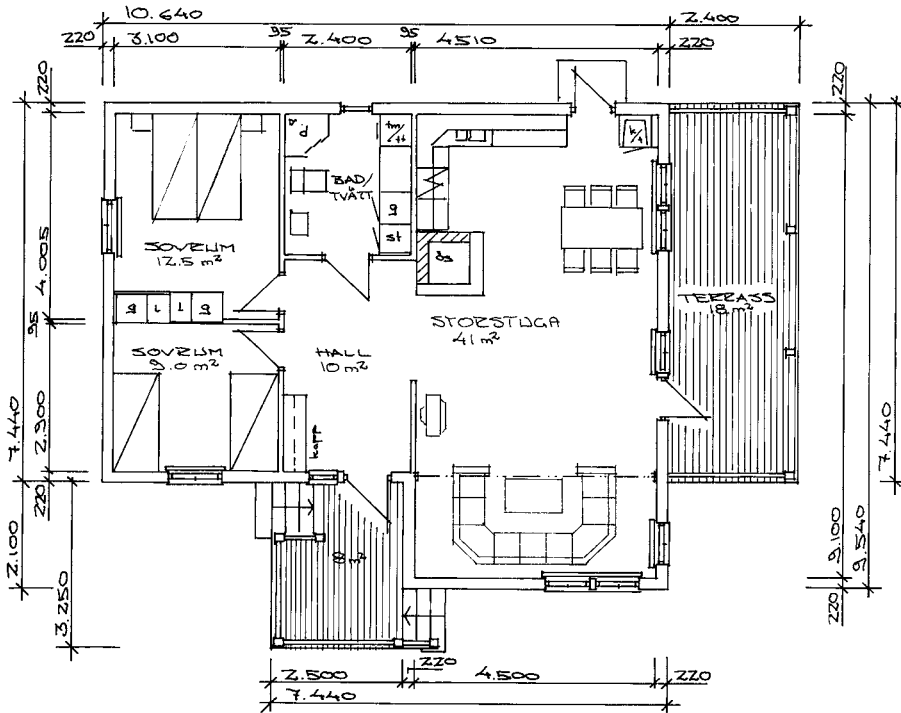

PLAN BOTTENVÅNING

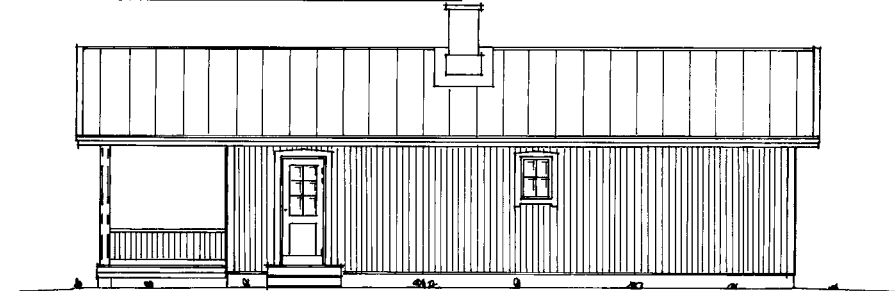

LÅNGFASAD

TERRASSEN KAN
LITFÖRAS
INGLASAD

IVÄNDIG
PLANKÖSLING
KAN ÄLDRA S
EMLIGT
KULDETS
ÖKEMÅL
BYA 30 M²
ÖPA 26 M²

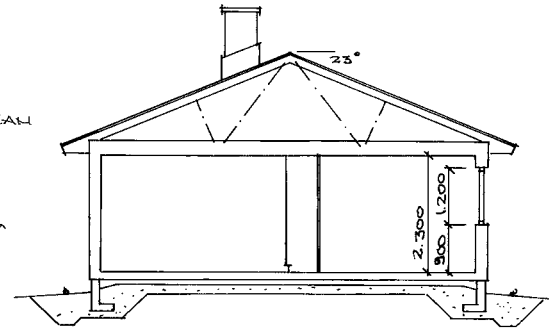

SEKTION

GRUNDLÄGGNING KAN
LITFÖRAS MED ALT
TORPABEHOVD ELLER
PLINTGRUNDLÄGGNING

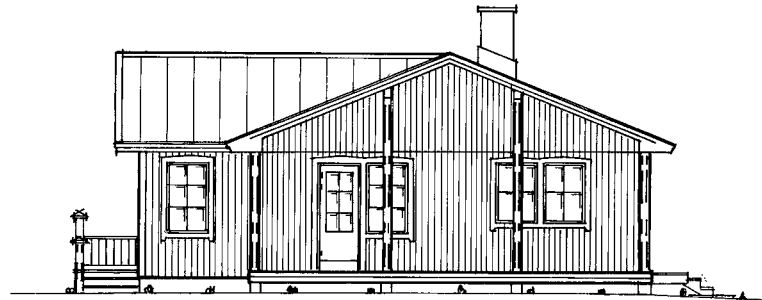

GAVELFASAD

LEVERANSALTERNATIV 1

FRITIDSHUS HARSPRÅNGET
PLAN, FASADER BYA 90 m²
OCH SEKTION ÖPA 26 m²

Redat av Sixten Eiström tel 0926-10330
Överkalix

30-25

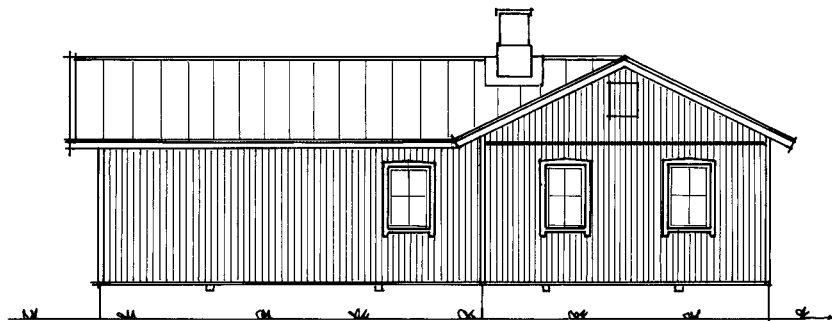

LÅNGFASAD

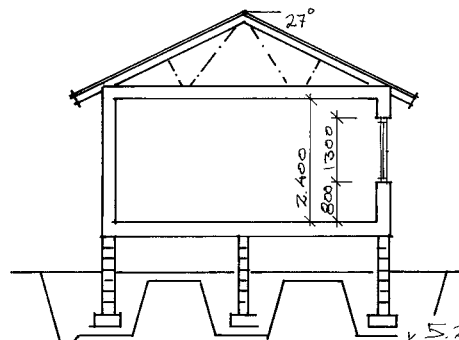

SEKTION

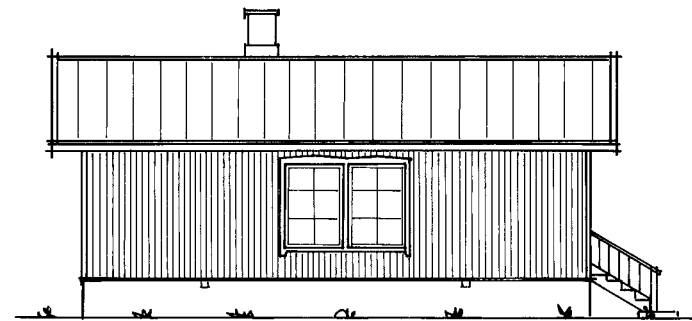

SIDOFASAD

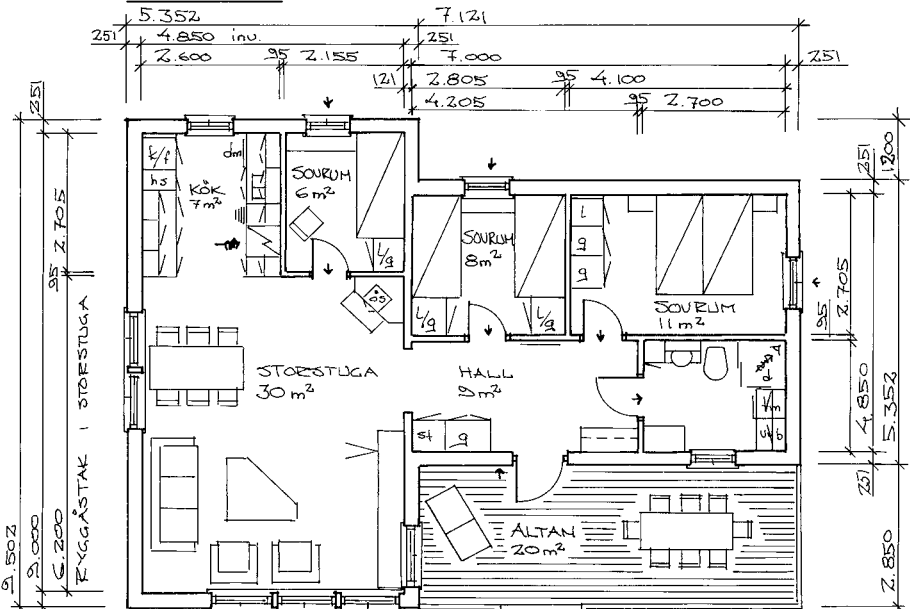

PLAN

BYA 90 3/2
BOX 79 3/2

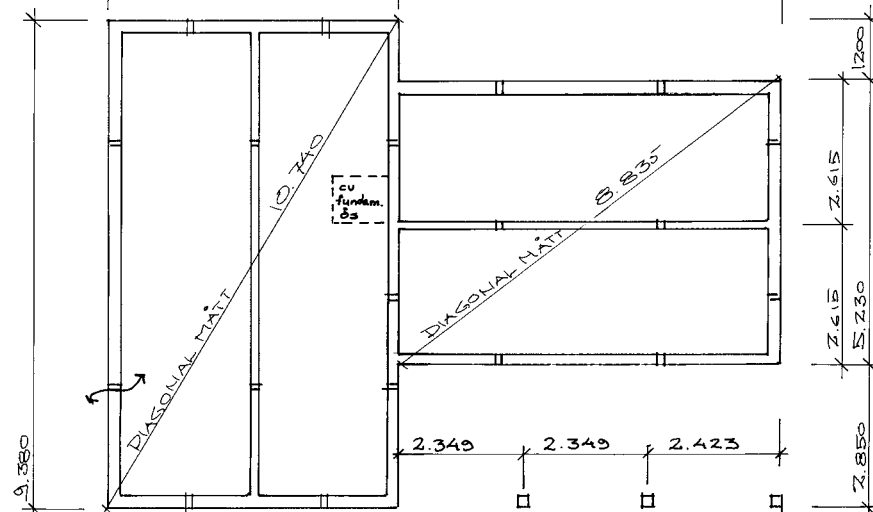

GRUND PLAN

LEVERANSALTERNATIV 2 VILLAISOLERING



ENTREFASAD

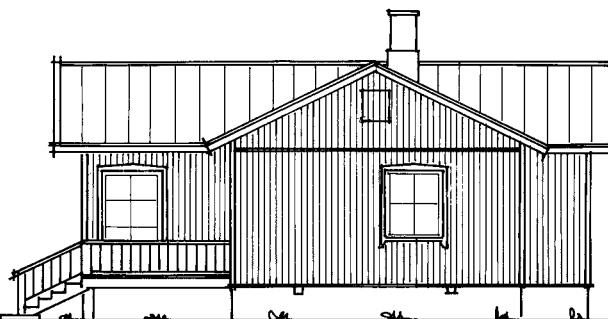

SIDOFASAD

FRITIDSHUS BÅNKRÖKEN BYA 90 m²

PLAN, FASADER,
SEKTION OCH
GRUND PLAN

Ritad av Sixten Riström tdl 0926-7721
Överkalix

30-26

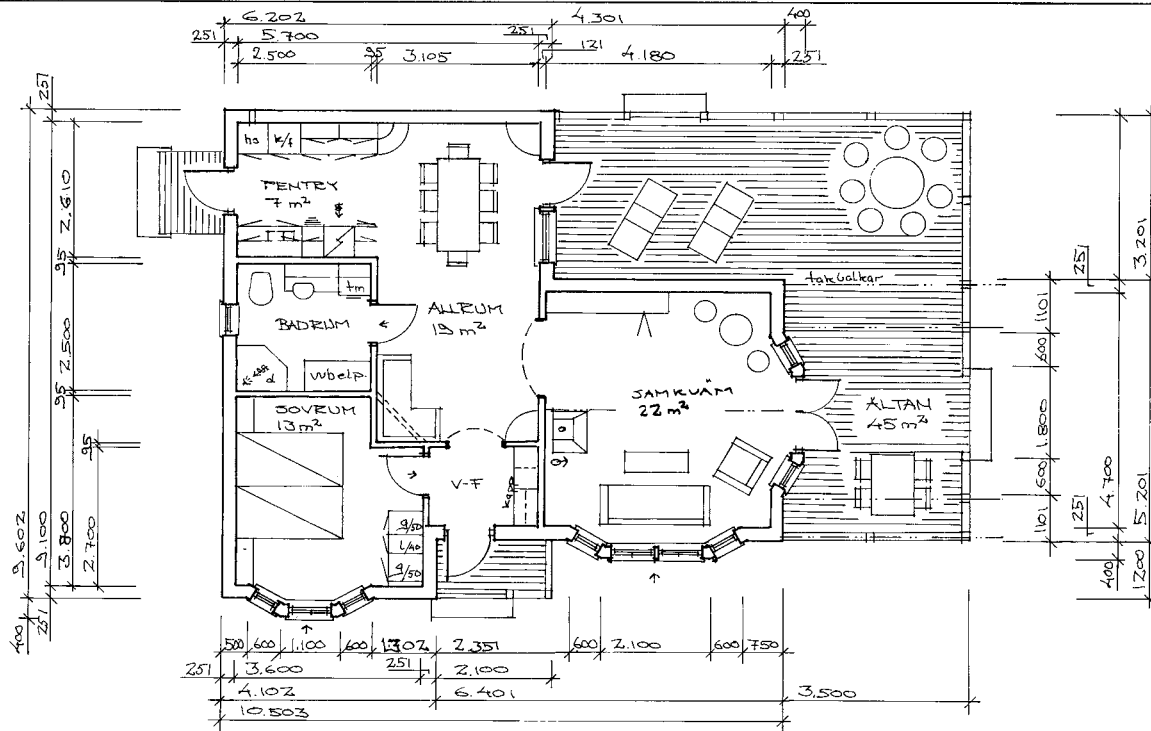

PLAN

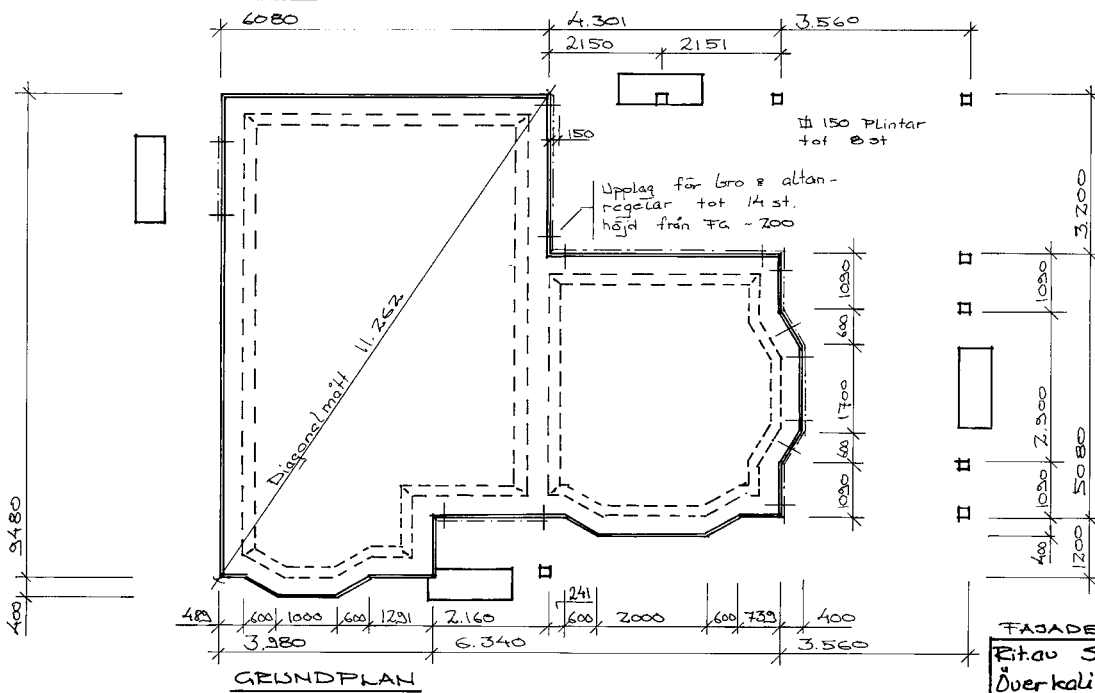

GRUNDPLAN

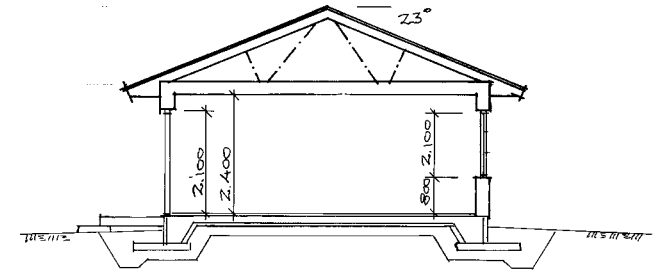

SEKTION

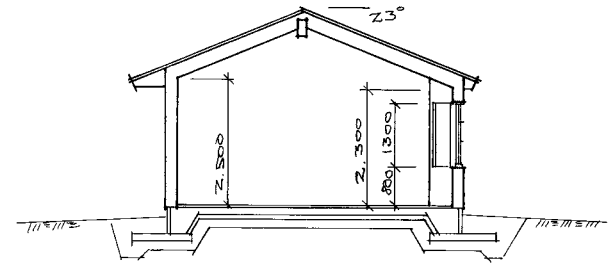

LEVERANSALTERNATIV 2 VILLAISOLERING

FRITIDSHUS KROKFORSEN BYA 83 m²
 PLAN, GRUNDPLAN
 OCH SEKTIONER ÖPA 21 m²

FASADER SE RITNING 26/30-02
 Rit av Sixten Riström tel 0926-77721
 Överkalix

30-27



FASAD MOT NORDÖST

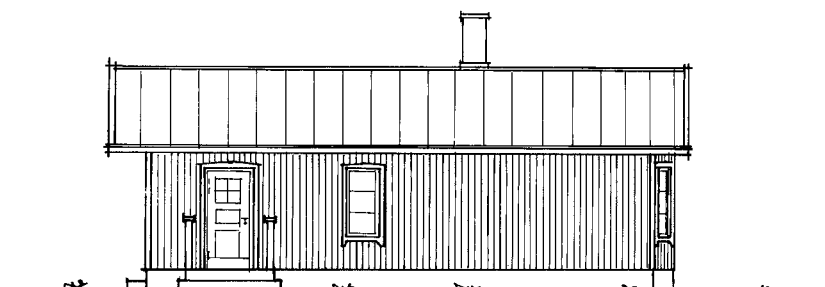

FASAD MOT SÖDÖST

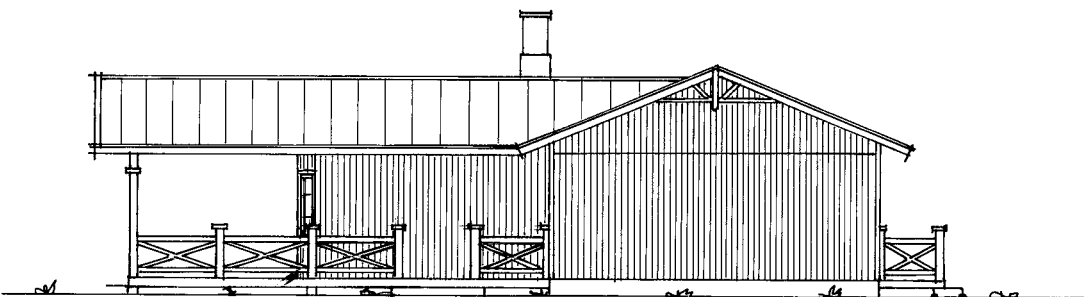

FASAD MOT SÖDVÄST

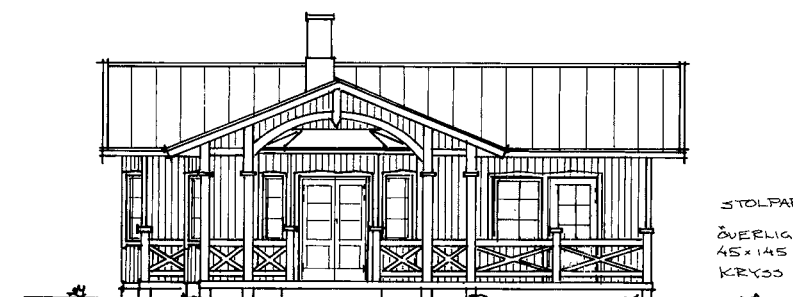

FASAD MOT NORDVÄST

STÖLPAR II 145
ÖVERLIGGARE
45x145
KRYSS 45x95

PLANER OCH SEKTIONER
SE RITNING SB/30-01

FRITIDSHUS KRÖKFORSJEN BYA 83m²
ÖPPA 21m²

FASADER

Ritad av Sixten Riström tel 0926-77721
Överkalix

30-28

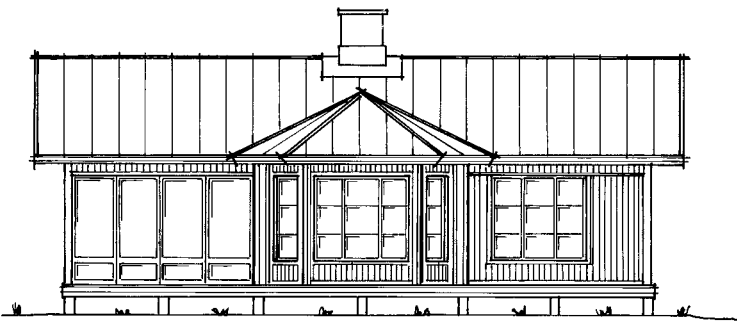

FASAD MOT SÖDER

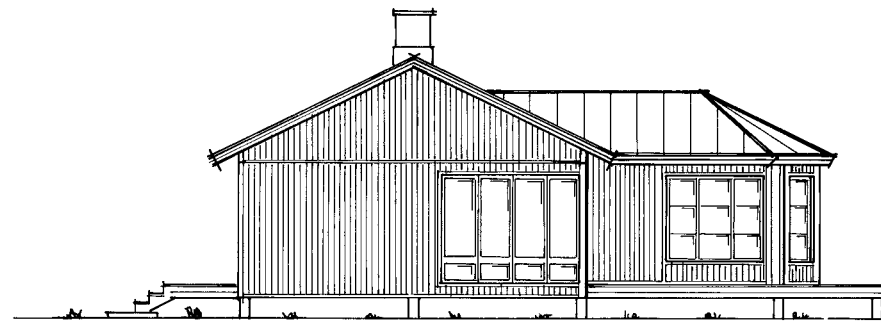

FASAD MOT VÄSTER

STÖRSTUGAN, KAN
BEHOV ENDE PÅ
TÄRKNIVA TRAPPAS
NER OCH SAMTIDIGT
KAN TAKET HÅLLAS
FÖR ERHÅLLANDE
AV INNEBALKONG
MED ANGRÄNSANDE
TAKBASTU.
ALTERNATIVT KAN
ATTELJEUTFORMNING
LTFÖRAS MED
LITÖKAT RYMMLIG-
HUSKÄPP.

FRETTIDSHUSET
FÅR MED DETTA
EN MER FÄGELLIG
STUKTUR "ÖRNEN"
OCH PASSAR DÅ
BÄTTRE IN I TERRÄNG
MED SENVUXEN FUR
ELLER GRANSKOG

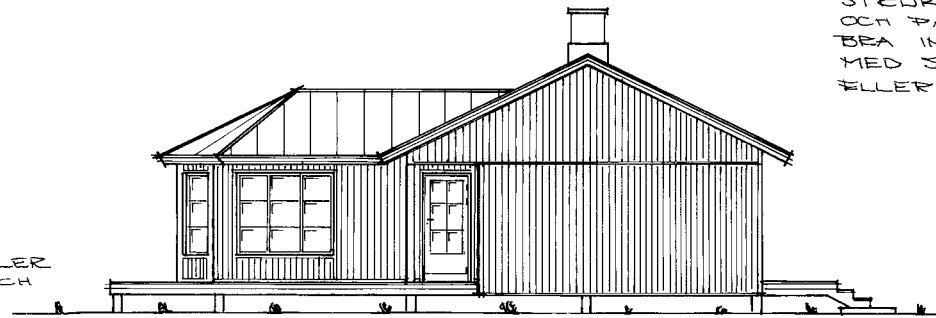

FASAD MOT ÖSTER

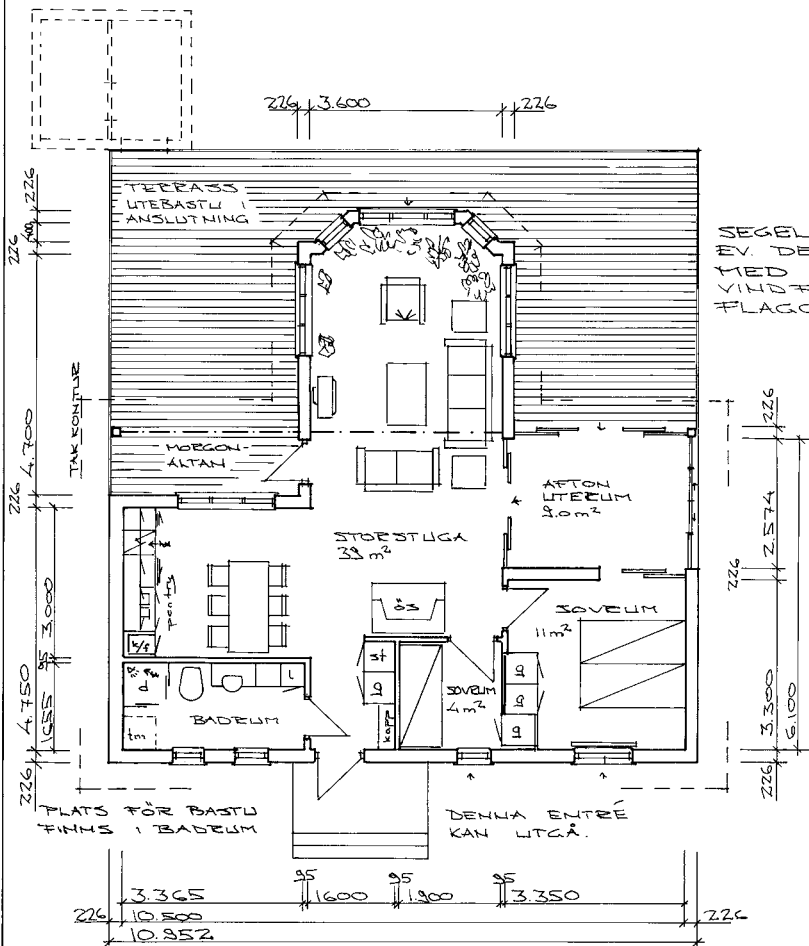

SEGELPAVILJON
EV. DEKORFÄCKE
MED SJÖSYMBOLER
VINDFLÖTTEL OCH
FLAGGSPEL

INNERTAK KAN
LTFÖRAS "BUTET"
ELLER
LIT ÖLSKEMÅL

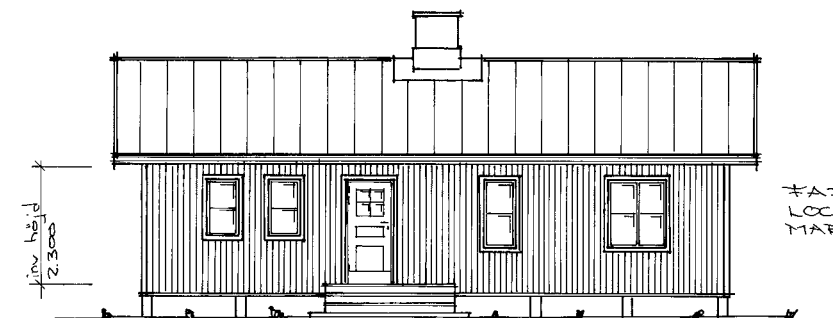

FASAD MOT NORR

FASAD AV STÄNDE
LOCKPANEL MED
MARKERBANDE FÖDER

LEVERANSALTERNATIV 1

FRITIDSHUS JOKKFALL BYA 85m²
PLAN, FASADER, ÖPA 7m²
OCH SEKTION

Ritad av Sixten Riström tel 0926-77721
Överkalix

30-29

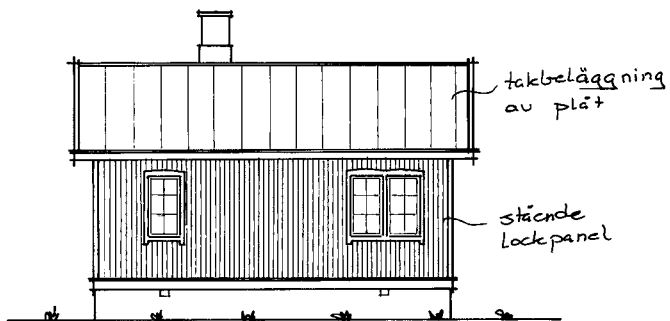

SIDOFASAD

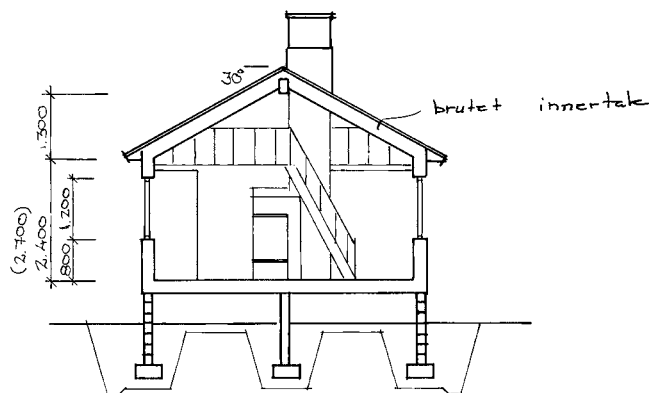

SEKTION

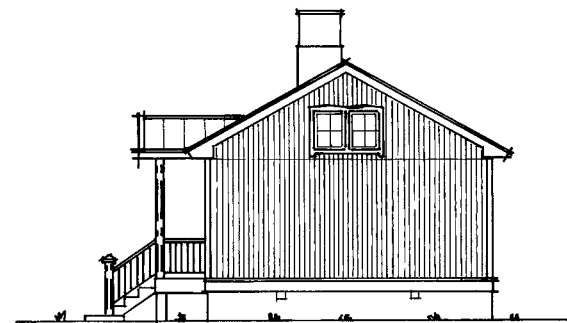

GAVELFASAD

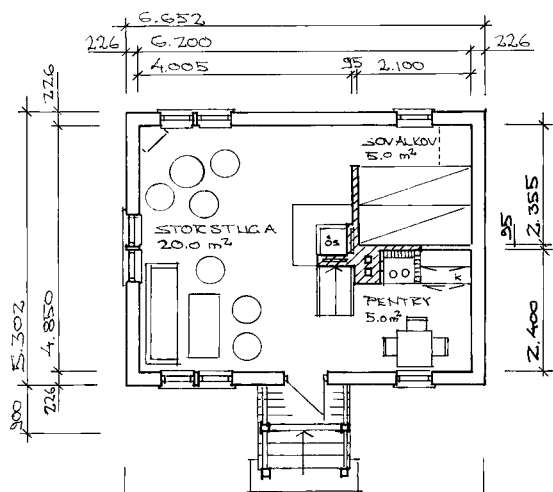

PLAN BOTTENVÅNING

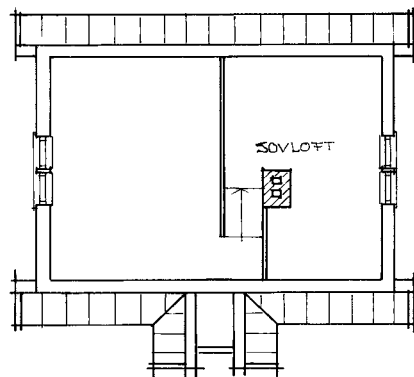

PLAN SOVLOFT

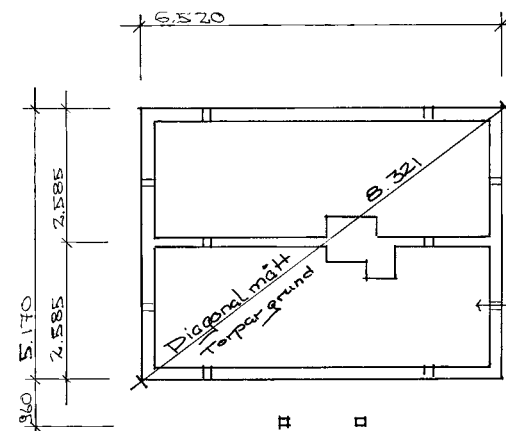

GRUNDLÄGGNINGSPÅN

LEVERANSALTERNATIV 1



ENTRÉFASAD

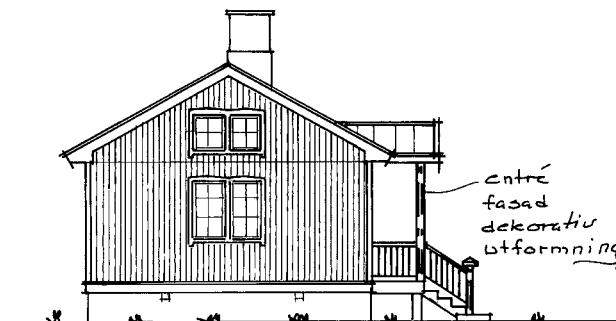

GAVELFASAD

FRITIDSHUS VÄNNÄSSTUGAN

PLANER, FASADER, SEKTION OCH GRUNDPLAN. BTA 35m²+ LOFTE

Ritad av Siden Riström tel 0926-77721 Överkalix



ENTREFASAD

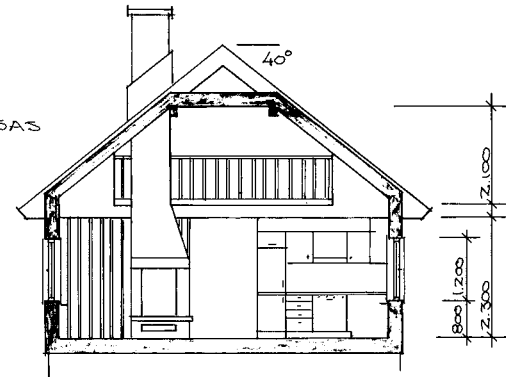

SEKTION



GAVELFASAD

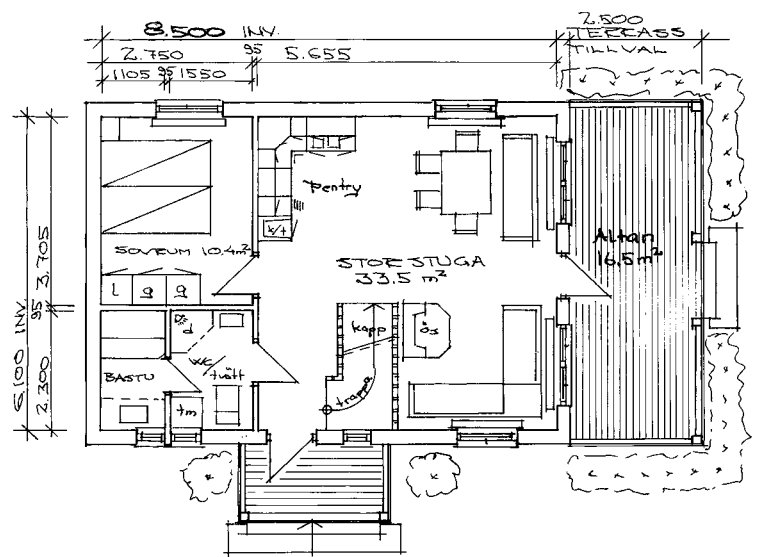

PLAN BOTTENVÄNING

BYGGNADSYTA 59 m²
ÖPPEN YTOR 16 m²
VÄNINGSYTA 75 m²

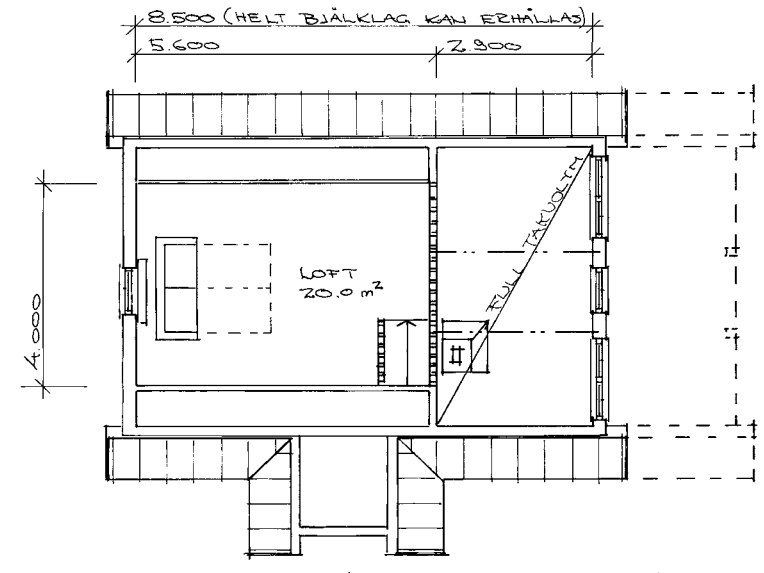

PLAN LOFET

LEVERANSALTERNATIV 1

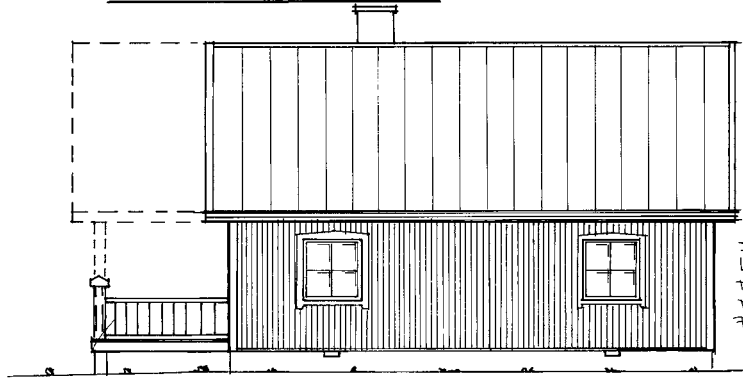

LÅNGFASAD

STÄNDE
LOCKPANEL
MED
MARKERANDE
FODER

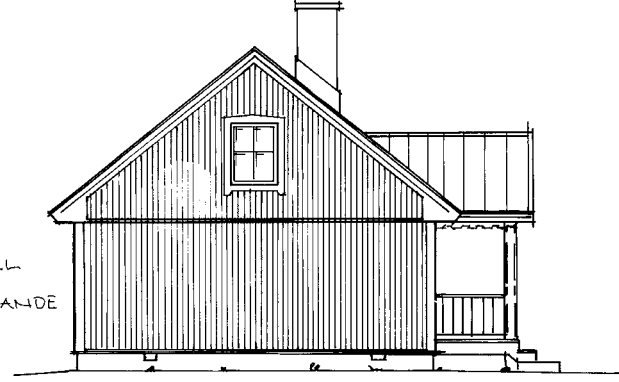

GAVELFASAD

FRITIDSHUS LINAFALLET BYA 59 m² +
PLÅNER, FASADER LOFT 20 m²
OCH SEKTION

Titlad av Sixten Eiström tlos26-77721
Övertalix

30-31

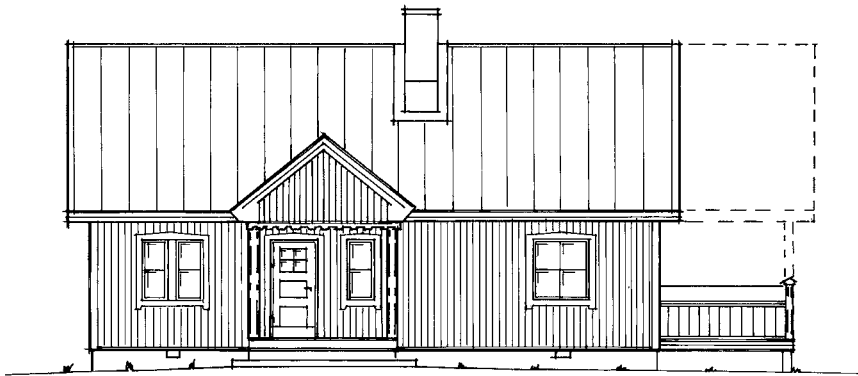

ENTREFA SAD

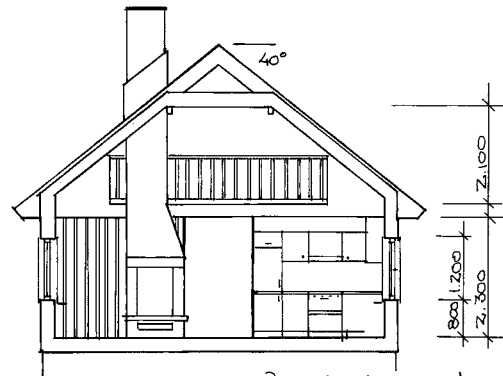

SEKTION

Valbart grund-
läggnings-
alternativ



GAVELTASAD

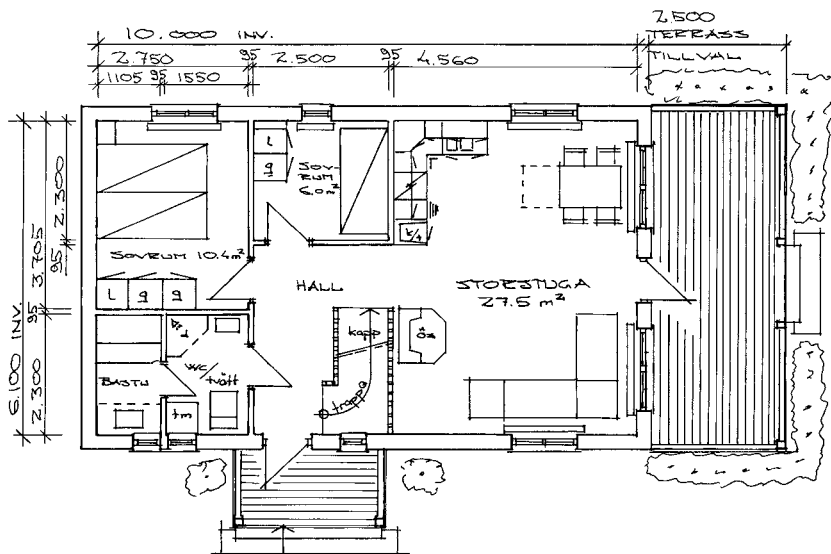

PLAN BOTTENVÅNING

TERRASSEN KAN
INGLASAS FÖR
ERHÅLLANDE AV
UTERUM.

BYGGNADSYTA 70 m²
ÖPPENYTA 16 m²
VÅNINGSYTA 88 m²

VÅR SPECIALITET
- VI SKRÄDDARSYR
ERT BOENDE

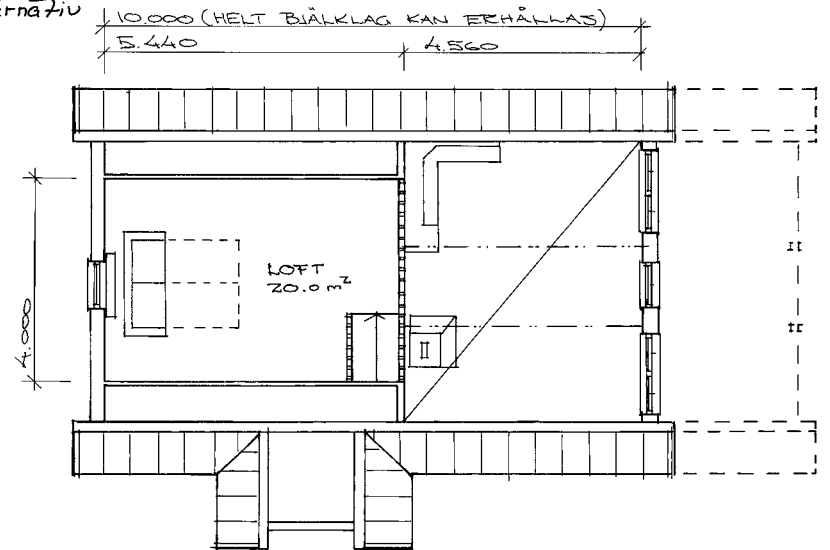

PLAN LOFTET

LEVERANSALTERNATIV 2 VILLABOLERN

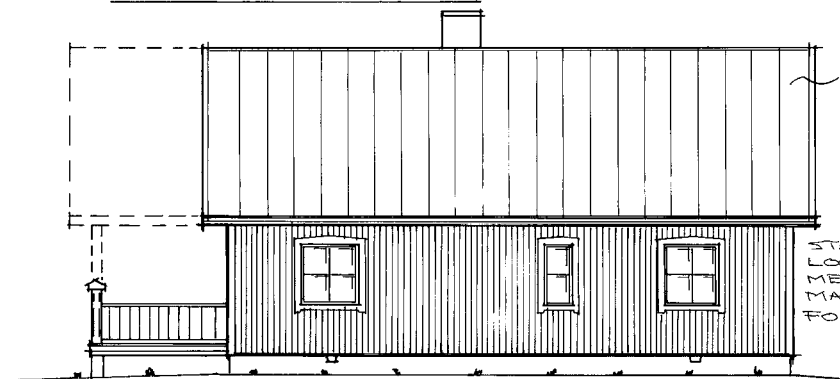

LÅNGFASAD

takbeläggning
av plåt

STÅENDE
LOCKPANEL
MED
MARKERANDE
FODER

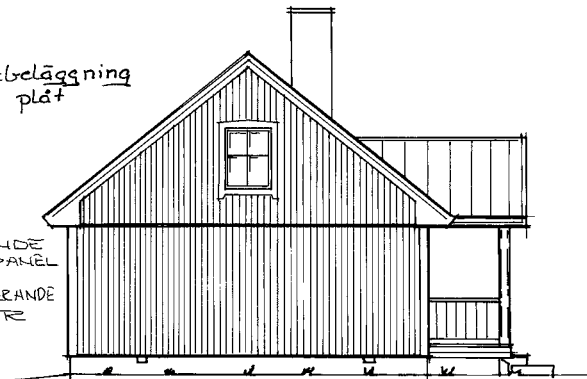

GAVELTASAD

FRIIDSHUS LINAFALLET BKA 70 m² +
Loft 20 m² +
PLANER, FASADER ÖPP 16 m²
OCH SEKTION

Ritad av Sixten Riström tel 0926-77721
Överkalix

30-32

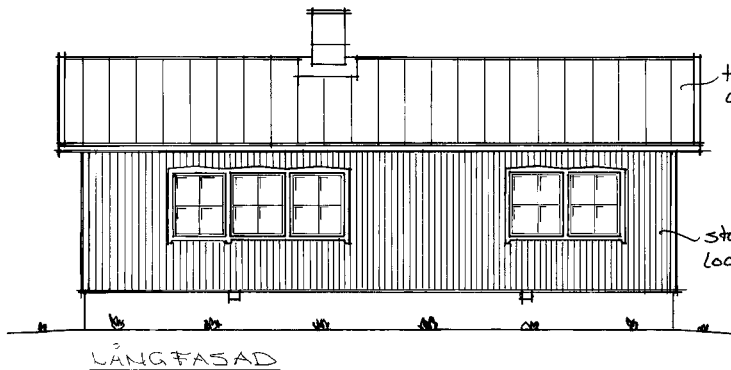

LÅNGFASAD

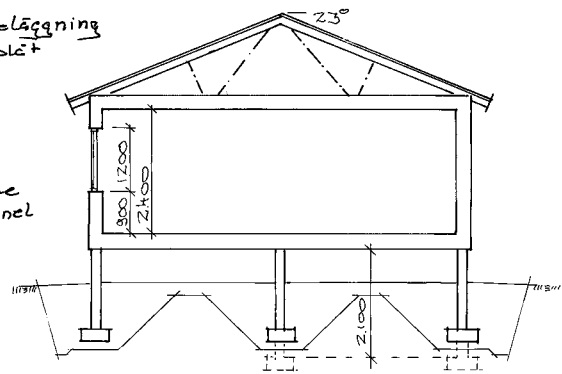

SEKTION

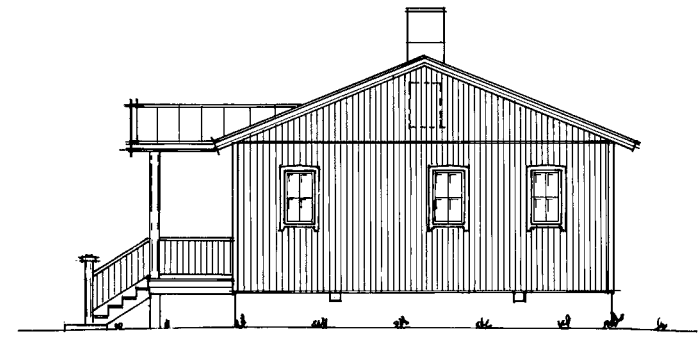

GAVELFASAD

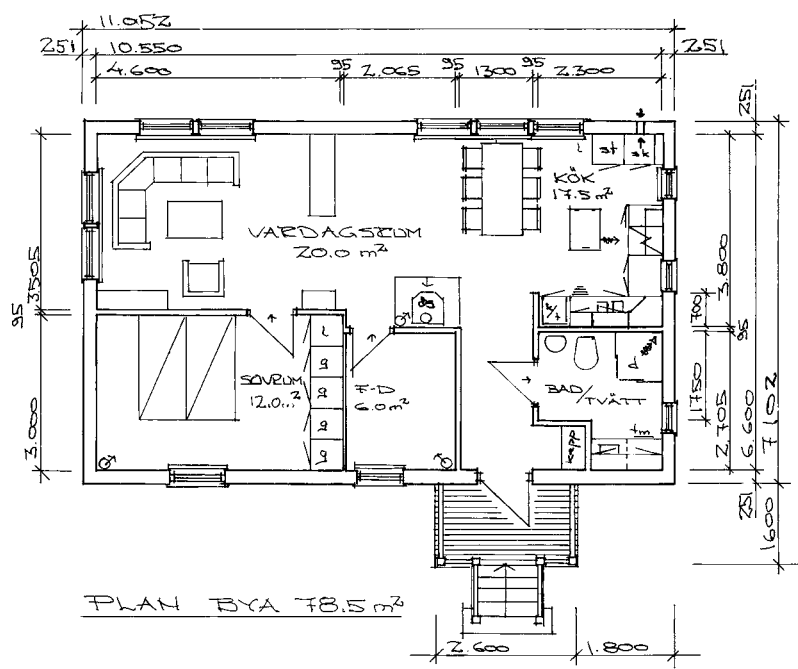

PLAN BYA 78.5 m²

$D_m - k_{rad} = 0.215$
 $D_m - medel = 0.206$

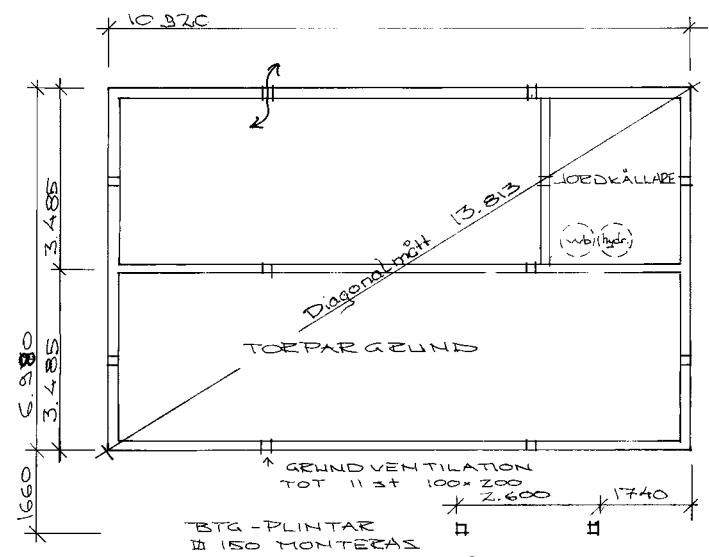

GRUNDPLAN

LEVERANSALTERNATIV 2 VILLAGOLEERING

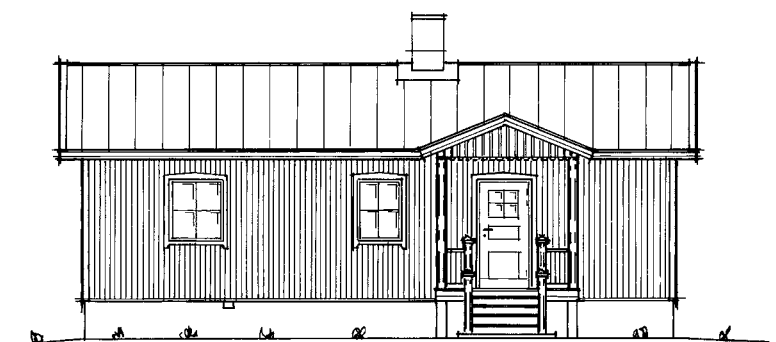

ENTREFASAD

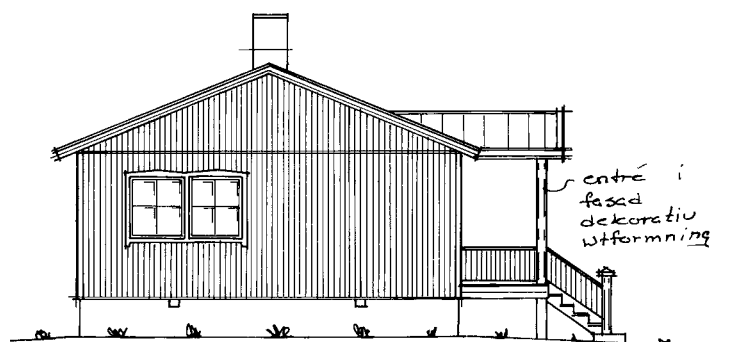

GAVELFASAD

EGNAHEM STORFORSEN BOA 70 m²
 PLAN, FASADER,
 SEKTION OCH
 GRUNDPLAN

Ritad av Sixten Riström tel 0926-11721
 Överkalix

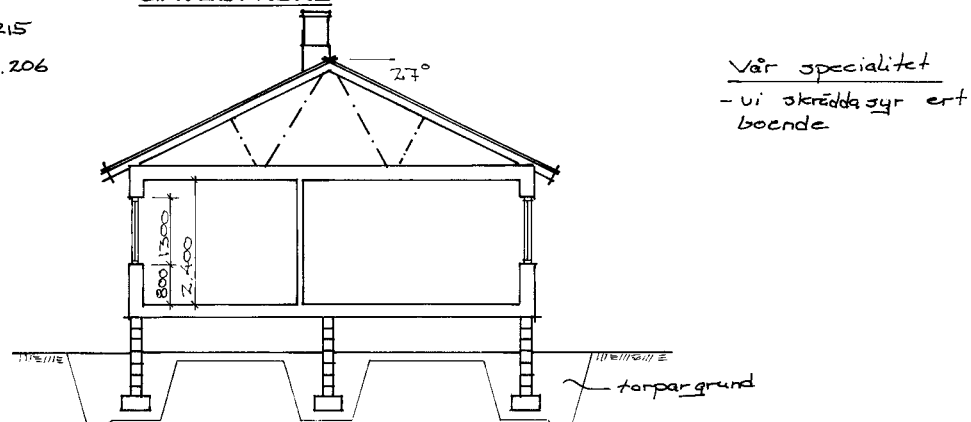
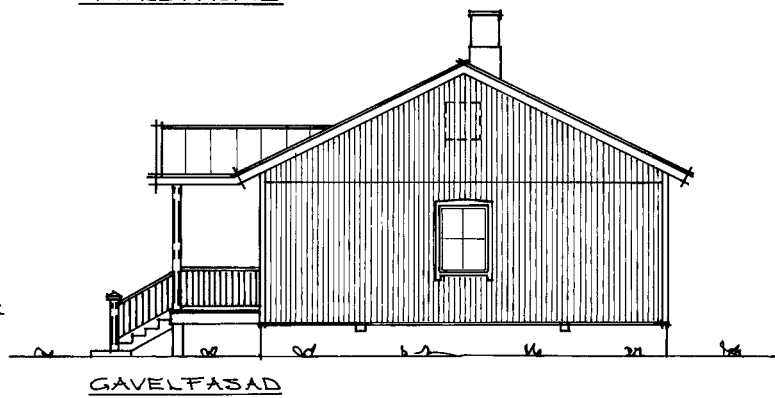
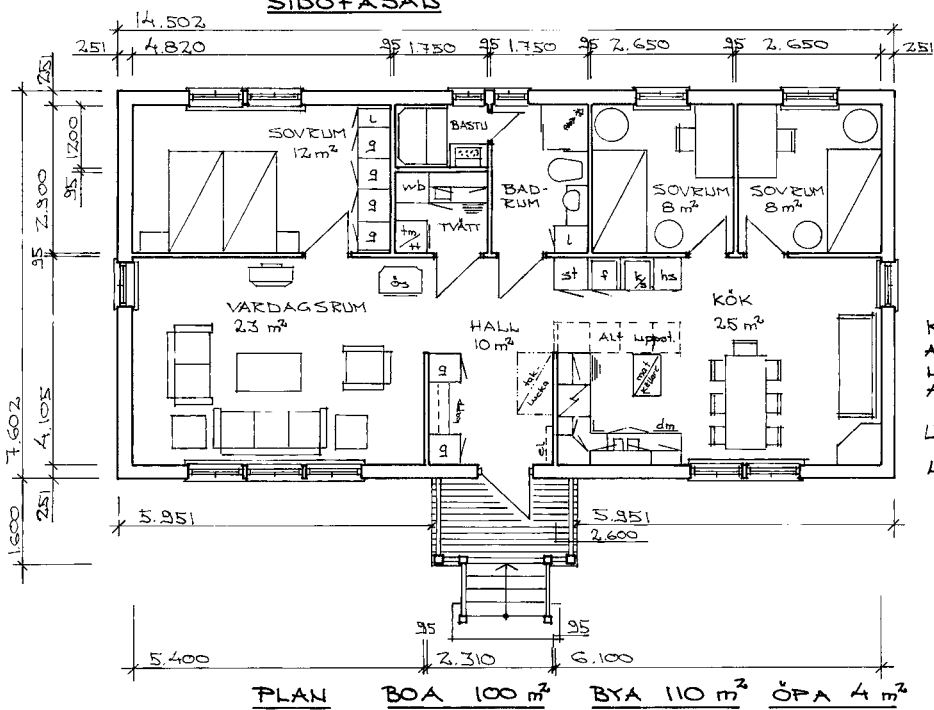
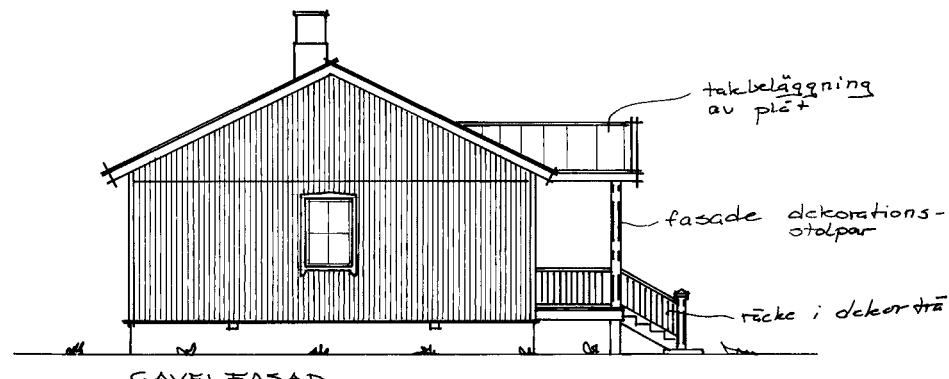
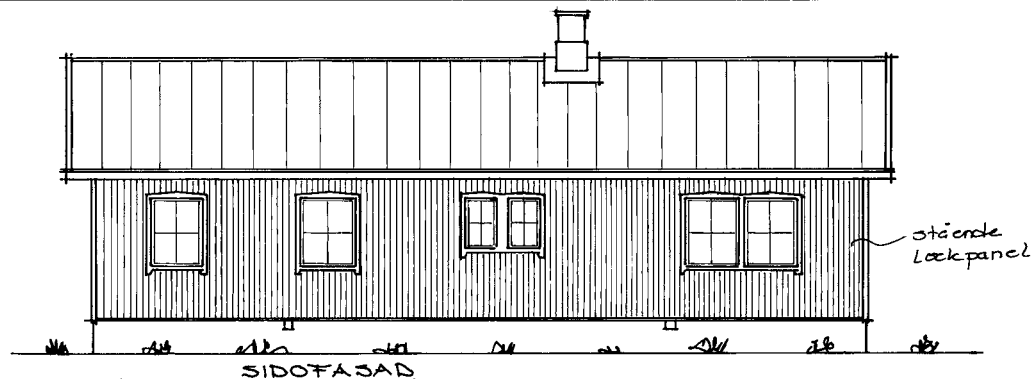

EGNAHEM FJÄLLSIPPAN BOA 100 m²
3 RUM & KÖK.
PLAN, FASADER OCH SEKTION

Ritad av Sixten Riström tel 0926-77721
Överkalix

30-34

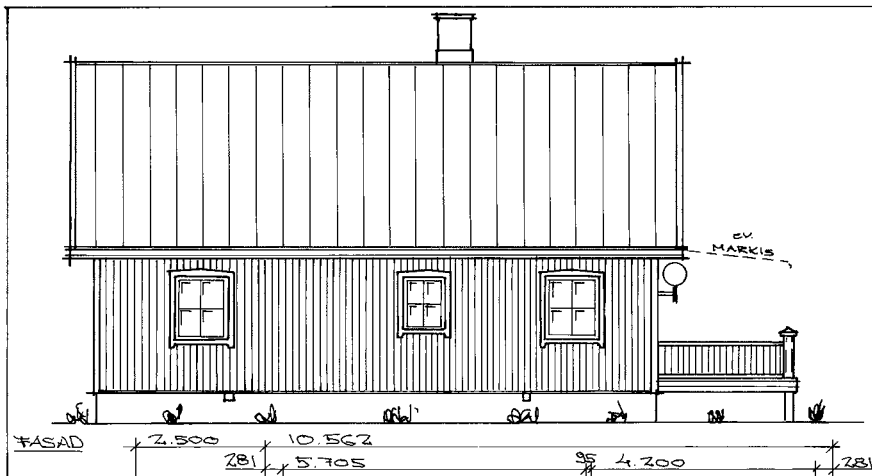

FASAD 2.500 10.562 281 5.705 4.200 281

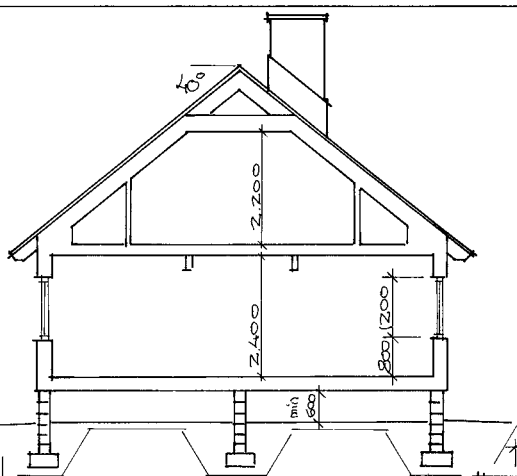

SEKTION

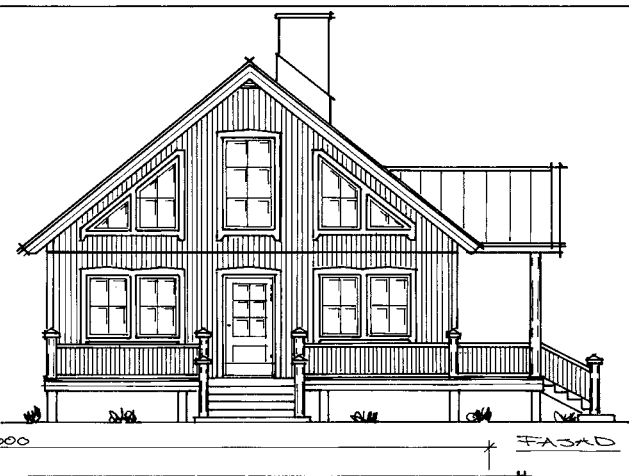

FASAD

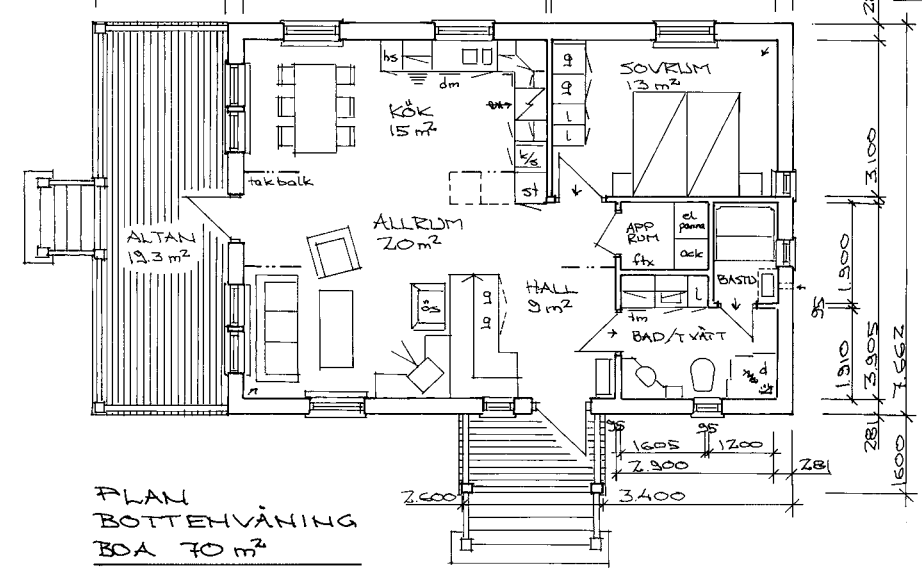

PLAN
BOTTNVÅNING
BOA 70 m²

LEVERANSALTERNATIV 2
VILLAISOLERING

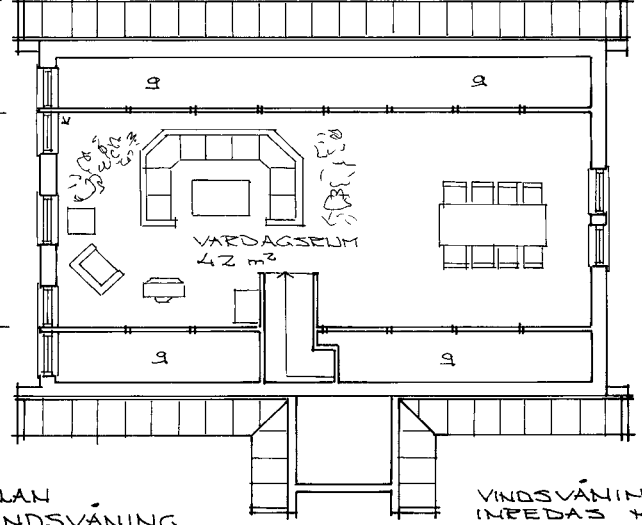

PLAN
VINDSVÅNING
BOA 42 m²

VINDSVÅNING KAN
INREDAS MED
2 SOVRUM + WC

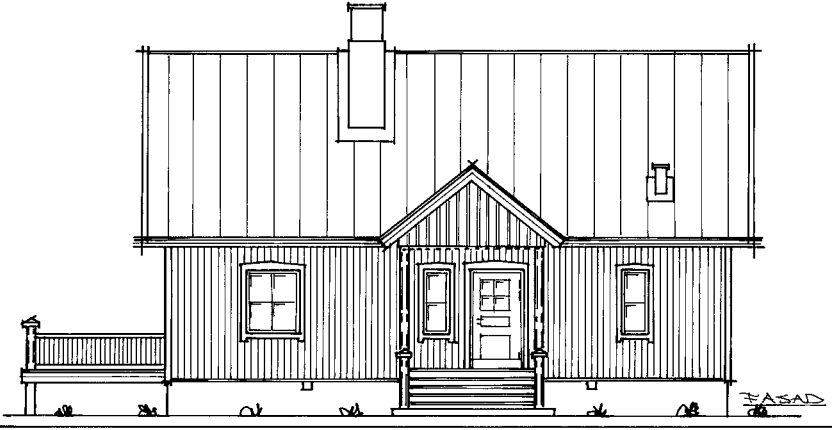

FASAD

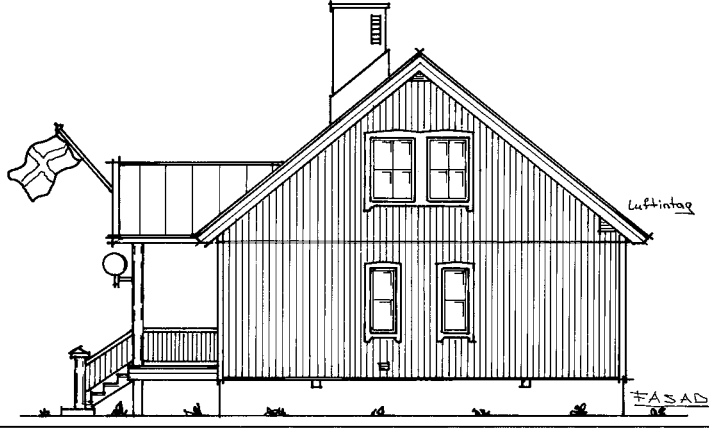

FASAD

EGNAHEM LINAFALLET BOA 112 m²
 PLANER, FASADET, SEKTION
 BYA 125 m². BOA 112 m² ÖPA 4 m²
 Ritad av Sixten Riström tel 0926-77721
 Övertalix

30-35

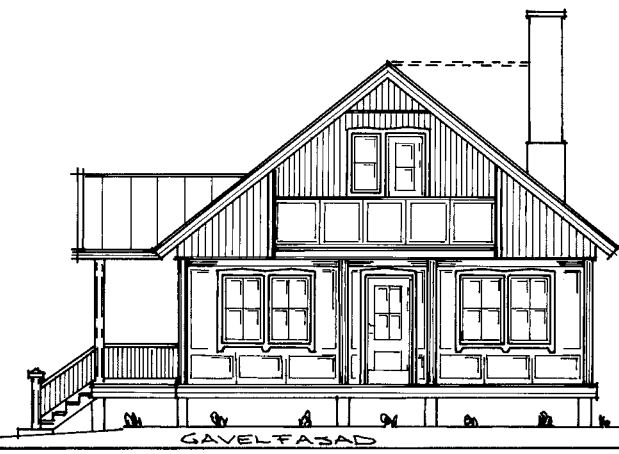
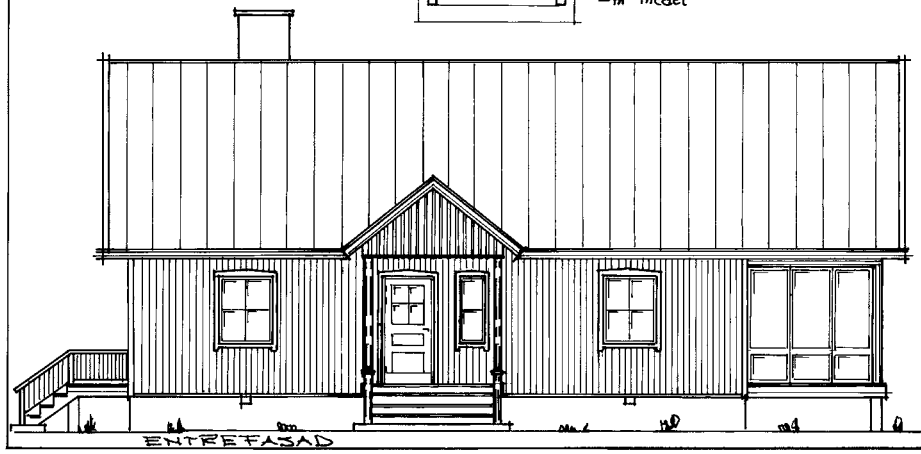
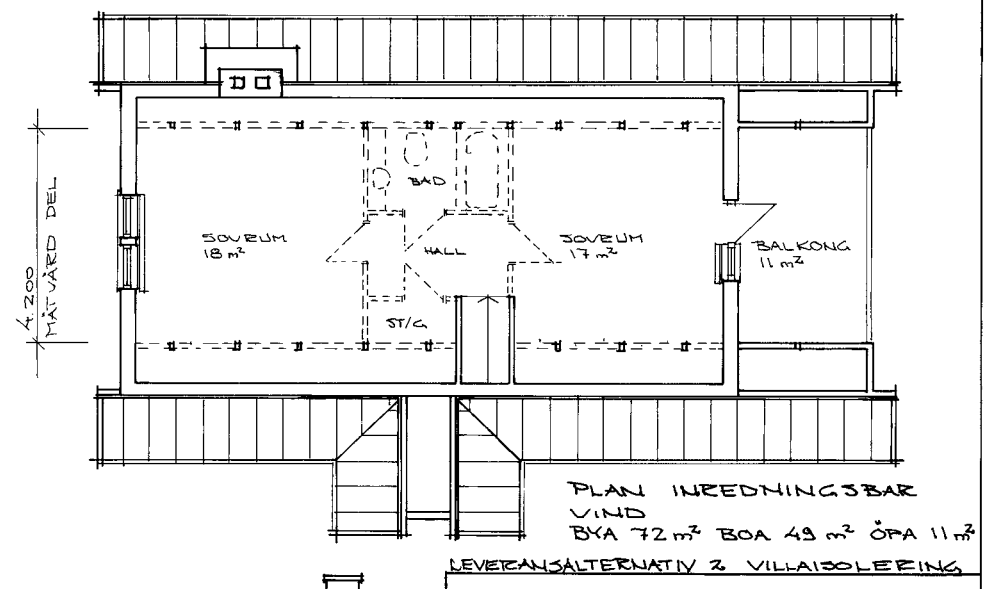
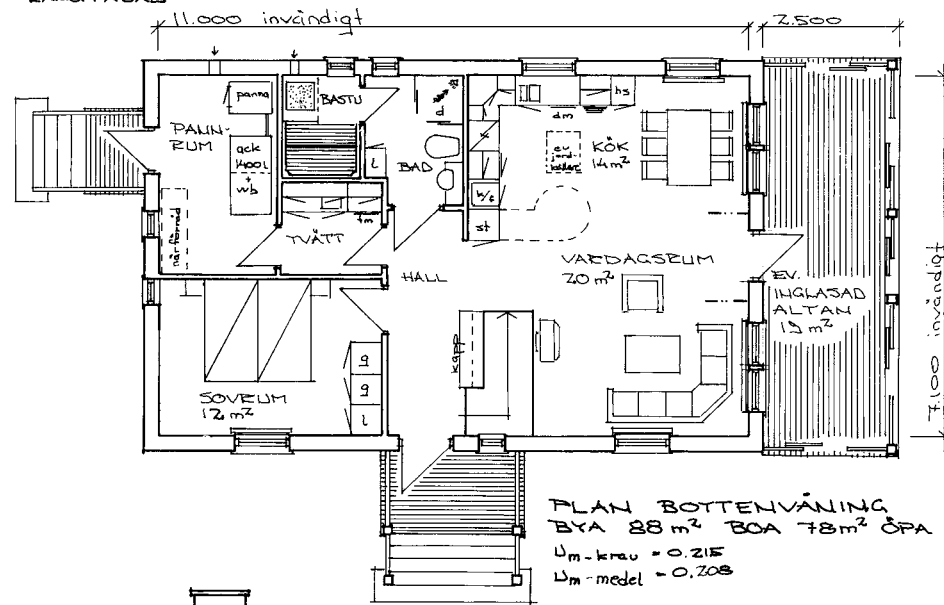
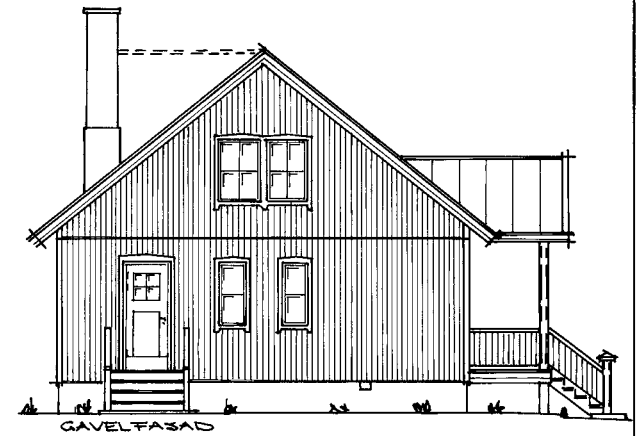
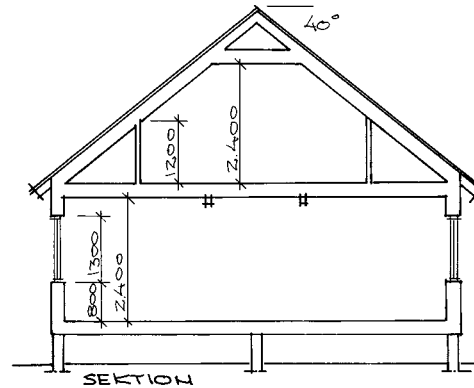
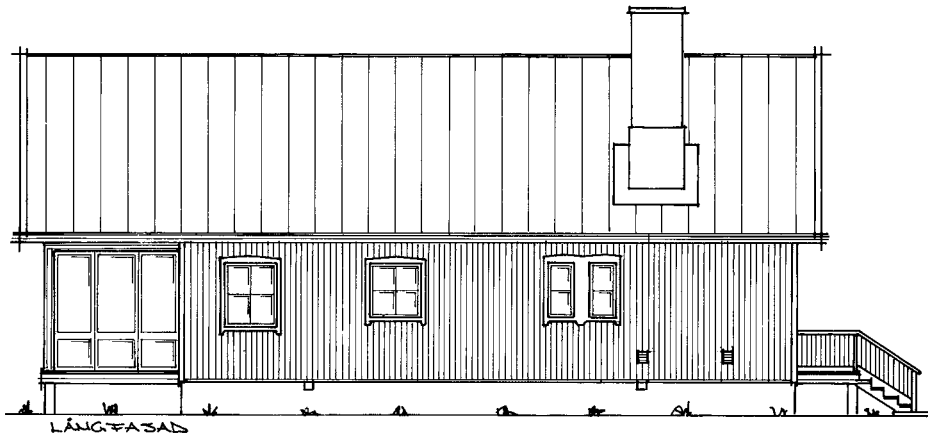

EGNAHEM LINAFALLET BOA 127 m²
 ÖPA 30 m²
 PLANER . FASADER . SEKTION
 Ritad av Sixten Riström tel 0926-77721
 Överkalix

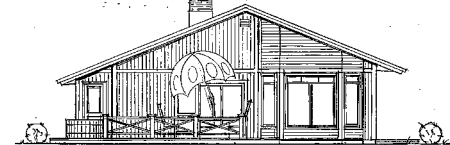
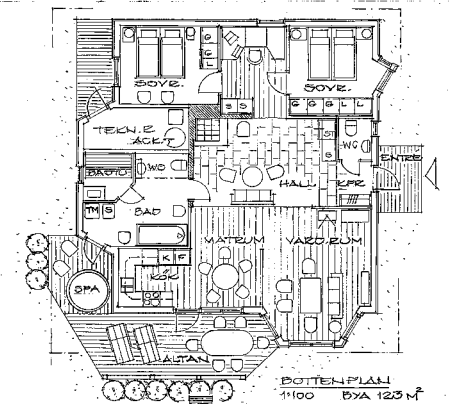
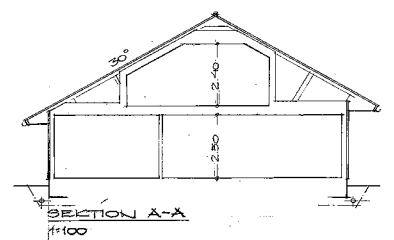
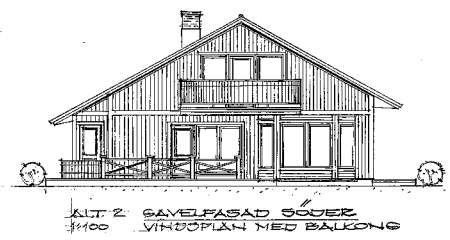
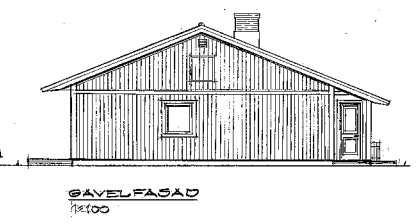
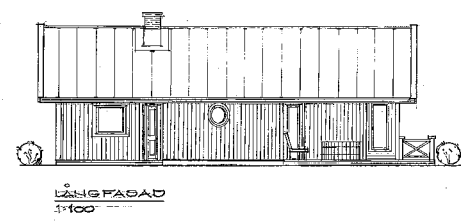
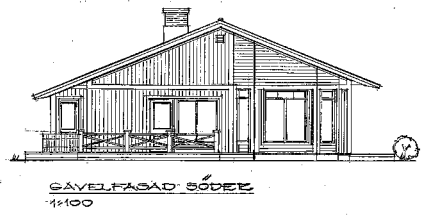
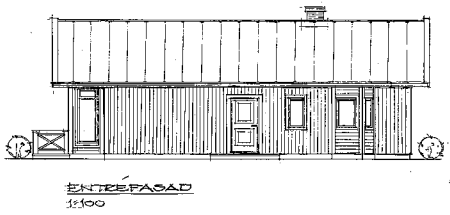
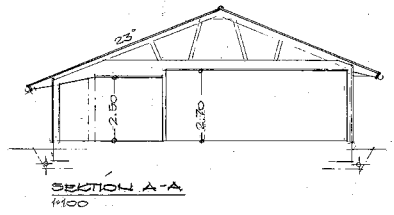
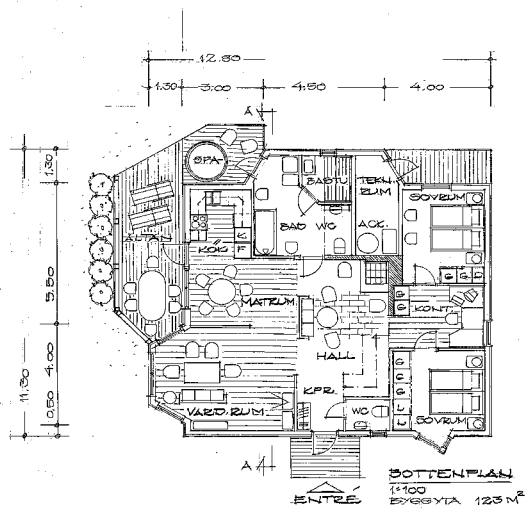

ANDERSSONS TRÄHUSFABRIK AB
VÄNNÄSBERGET 956 00 ÖVERKALIX

TEL. 0926-210 35

BYGGA 123 M ²	FRITIDSHUS
ENFAMILJESHUS/VINDÖPLAN	
PLÅN: FASADER, SEKTIONER	
BYGGA 123 M ²	
KONSTR. AV	SKALA 1:100
BYGGA 123 M ²	
BESTÄLLARE	TEL.
	DAT.
	SÖLÅREDA
	BYGGA 123 M ²
	REV 05-A4

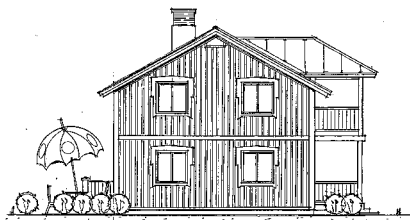
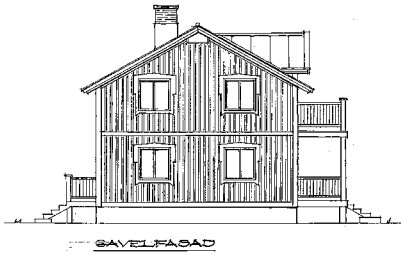
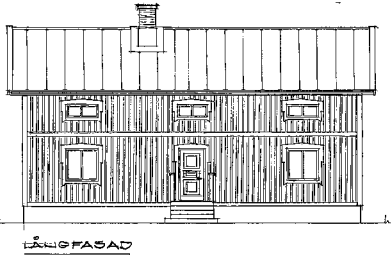
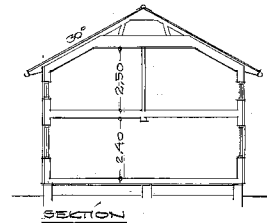
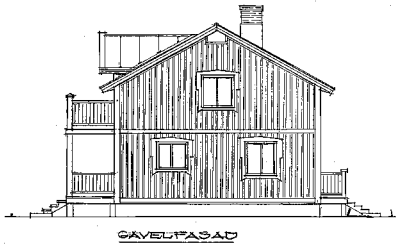
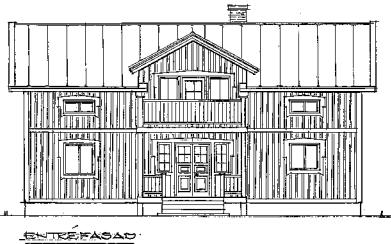
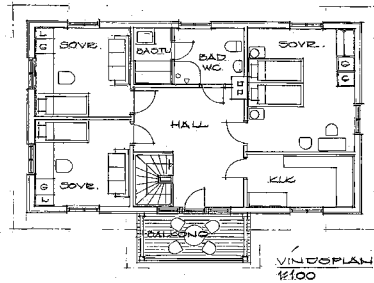
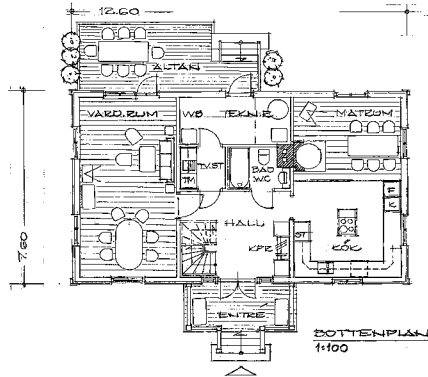

ALT. 2
SÄVELFASAD
TRÄG ÖVER BALKONG

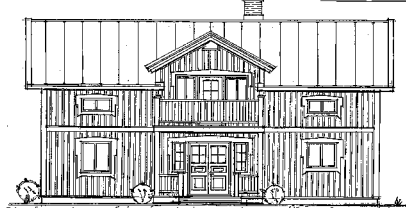
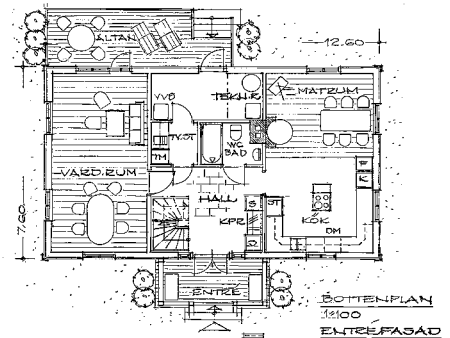

ANDERSSONS TRÄHUSFABRIK AB
VÄNNÄSBERGET 956 00 ÖVERKALIX

TEL. 0926-210 35

BYTTAD AV KONSTR. AV SKALA 1:100

BESTÄLLARE TEL DAT

ENFAMILJSHUS 7.60x12.60M
VÄNNÄSGÅRDEN
PLAN, FASADER, SEKTION
RITN.NR REV
06-A2

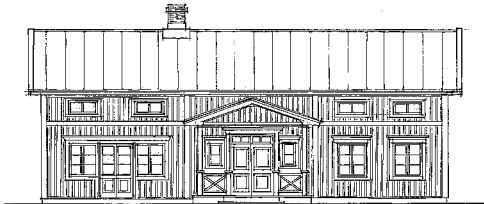
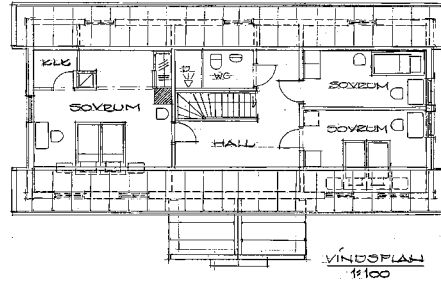
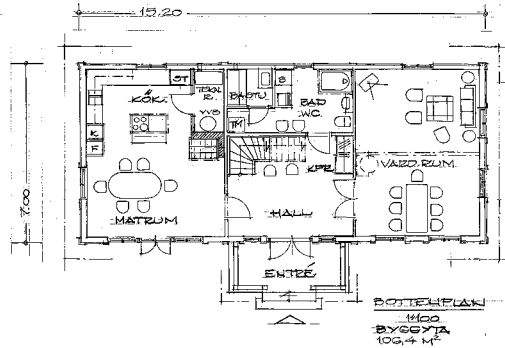

ENTREFASAD
1:100

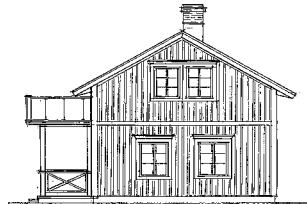

GAVELFASAD
1:100

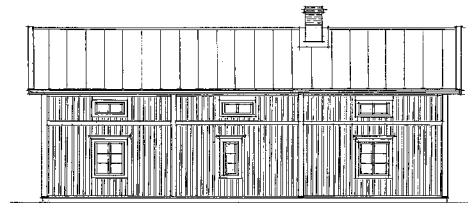
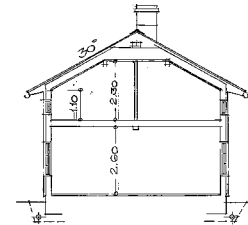

LÅNGFASAD

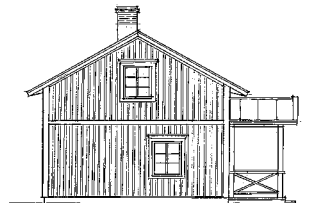

GAVELFASAD

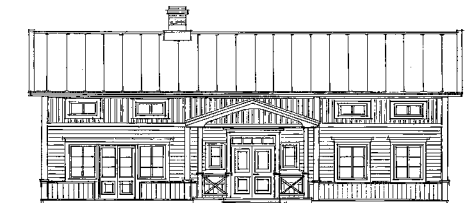

ALTERN. 2: ENTREFASAD

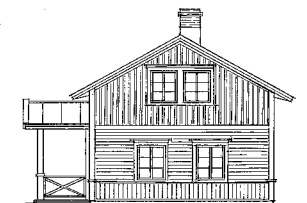

GAVELFASAD

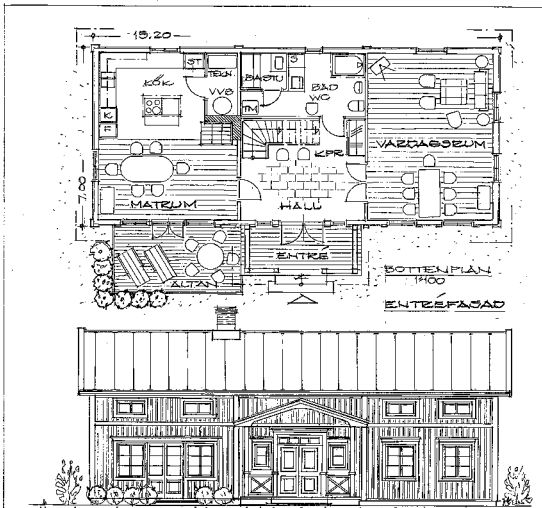

TEL. 0926-210 35	BYGGMÅTTSHUS 7,0x15,2 M
RITAD AV KONSTR AV SKALA 1:100	PLAN
BESTÄLLARE	FASAD
TEL	DAT 2006.03.31
	NOBBERG
	RITN NR 06-A1
	REV

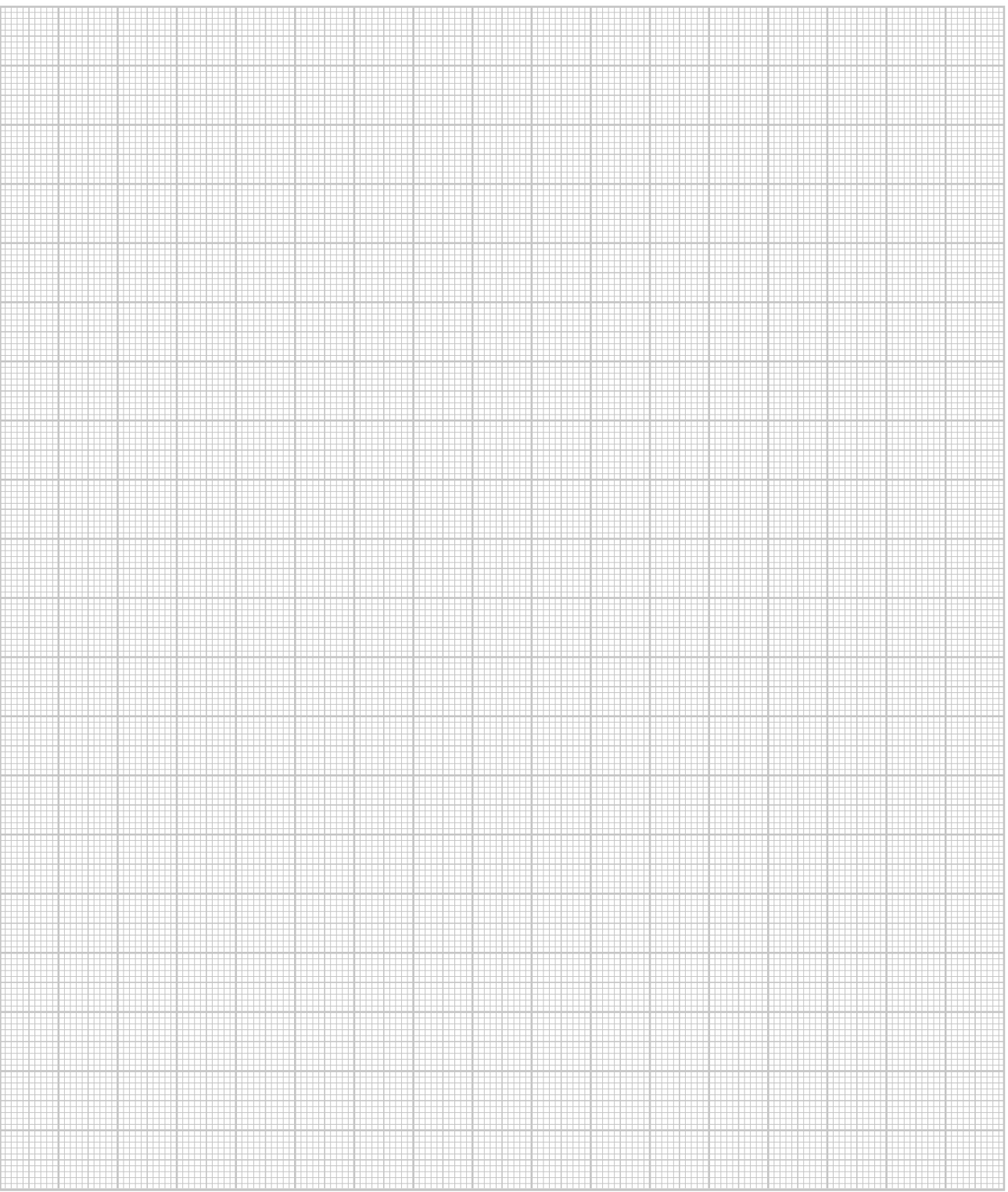

Ja, jag vill veta mer om Anderssons Trähus. Skicka broschyr snarast möjligt!

Namn:

Adress:

Postadress:

E-mail:

Har tomt. Läge:

Önskar broschyr på:

Villa-fritidshus

Garage-förråd

Övrigt

Skicka kupongen till:

Anderssons Trähusfabrik AB
Vännäsvägen 126, 956 92 Överkallix

.....
.....